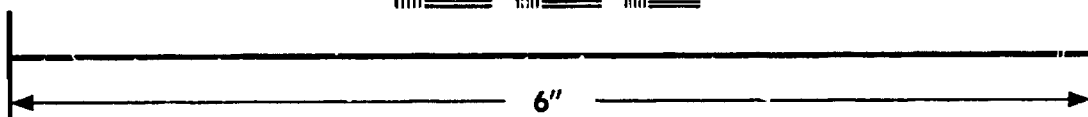
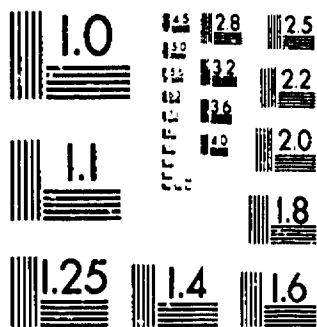
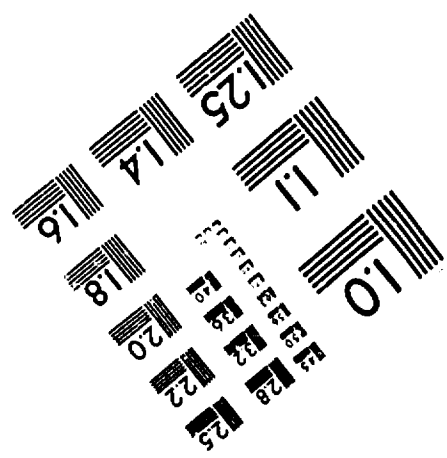
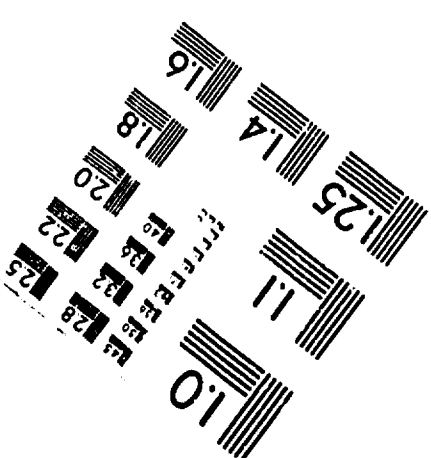

**IMAGE EVALUATION
TEST TARGET (MT-3)**



MICROCOPY RESOLUTION TEST CHART



PHOTOGRAPHIC SCIENCES CORPORATION
770 BASKET ROAD
P.O. BOX 338
WEBSTER, NEW YORK 14580
(716) 265-1600

LIST OF CONTENTS, FICHE IV

	Fiche
COINS, TOKENS, COUNTERS AND COIN-WEIGHTS IDENTIFIED by N.J. MAYHEW, DAPHNE NASH (NOS.1-2), S.E. RIGOLD (NUREMBERG JETTONS) AND MARION ARCHIBALD (NOS.9, 12)	A3
COPPER ALLOY AND SILVER OBJECTS (FIGS.112-22) by ALISON R. GOODALL; SPURS by BLANCHE ELLIS	B1
LEAD AND LEAD ALLOY OBJECTS (FIGS.123-24) by GEOFF EGAN, ALISON R. GOODALL AND GWYNNE OAKLEY	C11
IRON OBJECTS (FIGS.125-33) by IAN H. GOODALL; SPURS by BLANCHE ELLIS	D1
BONE AND IVORY OBJECTS (FIGS.134-39) by GEOFF EGAN AND MARTIN HENIG; IDENTIFICATION OF BONE AND IVORY by PHILIP ARMITAGE AND BOB WILSON	F1
WOODEN OBJECTS by GWYNNE OAKLEY; SPECIES IDENTIFICATION by M.A. ROBINSON	G1
GLASS (FIGS.140-43) by JEREMY HASLAM	G4
GLASS BEADS by JEREMY HASLAM	G10

COINS, TOKENS, COUNTERS AND COIN-WEIGHTS IDENTIFIED BY N.J. MAYHEW, DAPHNE NASH
(Nos. 1-2), S.E. RIGOLD (NUREMBERG JETTONS) AND MARION ARCHIBALD (Nos. 9 and 12))

Not illustrated

Site A : 1-38; Site B : 39-51; Site W : 52-54.

Site A, Church St.

1. Antoninianus, illegible, possibly 268-273 A.D. A SF2006, F17, L2010 Mid-late 17th-cent. context.
2. Barbarous radiate, late 3rd century A.D.: copy of Tetricus II Spes type. A SF1007, L2 (2M, 104/1012) Unstratified.
- 3-5. Nuremberg jettons of a type originally for use in Venice; early 16th century:-
 3. Obv : Lion of St. Mark (Venice), meaningless legend.
Rev : 'Reichsapfel' (orb in an ornamental tressure), meaningless legend. A nice early one: c.1505 \pm 10 years. A SF46/3, L70 16th-cent. context.
 4. Obv : Lion of St. Mark, meaningless legend GVRVIEGA (?) repeated.
Rev : orb in tressure, meaningless legend, ? same letters repeated.
c.1510 \pm 10 years. A SF46/2, L70, (2M, 118.5/995.7), 16th-cent. context found with No.3.
 5. Obv : Lion of St. Mark. Rev: Reichsapfel. c.1510 \pm 10 years, or could be later. A SF29, L2 (2M, 116/998) Unstratified..
6. Nuremberg jetton, c.1505-10 \pm 10 years.
Rev : Burgundian arms + 'briquet', close to archetype (Lady with the Marguerite) of an official Burgundo-Flemish jetton of the early 1490s.
A SF45, L2 (2M, 118/994) Unstratified.

COINS, TOKENS, COUNTERS AND COIN-WEIGHTS

7. Nuremberg jetton, 'ship penny' type c.1515 ± 15-20 years.
Obv : a three-masted ship, meaningless legend.
Rev : orb in ornamental tressure, meaningless legend.
A SF2055, F2008, L2007 Jetton dates context.
8. Nuremberg jetton, early or mid 16th century. Nonsense legends, orb in tressure (copied from S. German gold guilder or florin). Diameter 23mm.
A SF2026, F2504, L8 (= F2011) Early 17th-cent. context..
9. Copy of Nuremberg (Krauwinkel) jetton, c.1600. Illiterate legends, general type as Barnard¹ Pl.XXXIII, 82-3. Dented in centre. Diameter 24mm.
A SF2033, F2, L2011 Early-mid 17th-cent. context.
10. Nuremberg jetton, Wolf Laufer, 1618-60. Type not in Barnard.²
Obv : WOLF LAVFER RECHPF(ENIG?)....CF - rosette i.m. with three crowns and three lys.
Rev : Reichsapfel in tressure - GLVCK VND GLAS WIE BALD (??) CT DAS.
Diameter 22mm. A SF1050, F1023, L1120 Mid 17th-cent. context (+ some 17th-cent. material).
11. Lead token, roughly circular, cast in mould with raised rim and blob from filler. Probably not earlier than 17th century.
Obv : raised ?merchant's mark of crossed parallel lines.
Rev : between parallel raised lines - letter W or retrograde S or figure 3. Diameter 16.5-17mm. Illustrated with Lead Objects, No.1.
A SF1029, F60, L34 Mid 18th-cent. context.
12. Henry VIII, posthumous, issued under Edward VI, period 1547-50. Penny, Canterbury mint. Roman lettering. Wt. 0.47gm (7.2gr). Very little wear before deposition, probably before c.1560. A SF83, F78, L97 16th-cent. context.

1. F.P. Barnard, The Casting Counter and the Counting Board, (1916).

2. Ibid.

COINS, TOKENS, COUNTERS AND COIN-WEIGHTS

13. James I Lennox farthing, 1614-25.
Obv : IACO D.... - crown over crossed sceptres.
Rev : FRA....R (EX) - crowned harp. Diameter 16mm.
A SF94, L2 (2M, 116/1014) Unstratified.
14. Charles I Richmond series farthing,¹ 1625-34.
Obv : CARO D.G. - crown over crossed sceptres, struck off centre.
Rev : FRA.ET.HIB.REX - crowned harp. Diameter 16mm.
A SF2001, L2, (1M, 99/1007) Unstratified.
15. Charles I 'Rose' farthing,² 1636-44.
Obv : CAROLVS etc. - crown over crossed sceptres.
Rev : FRAN.ET.HIB.REX. - crowned rose. Initial mark star or mullet.
Diameter 13-14 mm. A SF50, L2, (2M, 118/996) Unstratified.
16. Charles I 'Rose' farthing, 1636-44. Initial mark star or mullet. Squarish flan, split at edge. Diameter 13-14mm. A SF37, L2 (2M, 104/1004) Unstratified.
17. Charles I 'Rose' farthing, 1636-44. Initial mark crescent. Diameter 14.5mm. A SF1039, F1003, L1027 13th-cent.context. (+ intrusive post-medieval material).
18. Charles I 'Rose' farthing, 1636-44. Initial mark illegible. Diameter 13-14mm. A SF26, L2 (2M, 116/1012) Unstratified.
19. Probably Charles I 'Rose' farthing, 1636-44. Squarish flan Diameter 12-14mm. A SF1031, F60, L34 Mid 18th-cent. context.

1. C.W. Peck, English Copper, Tin and Bronze Coins in the British Museum, 1558-1958, (1960), 52.

2. Ibid. 74-75.

COINS, TOKENS, COUNTERS AND COIN-WEIGHTS

20. Thomas Combes, Oxford, farthing token, (1652 or) 1656-1661.
Obv : THOMAS. COMBES. NEARE - the Grocers' arms.
Rev : THE. EAST. GATE. IN. CXON. - T.C.
Leeds¹ No. 37. Diameter 16mm. A SF1, F17, L15 Mid-late 17th-cent. context.
21. John Bishop, Oxford farthing token, 1657.
Obv : (IOH: BISHOP: AT. YE). G (VIL)T - a looking glass (faintly discernible square). Rev : (star) OF (.OX)O(N.16)57 - 3 stars above (I.B 3 stars below). Leeds² No.23. Diameter 15-16mm (damaged). A SF35, L2 (2M, 118/994) Unstratified.
22. Charles II farthing. Obv : CAROLVS.A.CAROLO. Rev : Britannia. Date illegible but 1672-75. Diameter 21.5-22mm. A SF506, F45, L171 Mid-late 17th-cent. context.
23. Charles II farthing. 1672-75. Diameter 22mm. A SF2018, F2003, L2015 (=F17) Mid-late 17th-cent. context.
24. Copper farthing, after 1672, Charles II or up to George III.
Rev : Britannia. Diameter 22.5mm. A SF1051, F1023, L1120 Mid 17th-cent. context (+ some 17th-cent. material).
25. Possibly late 18th-century halfpenny token. Diameter 24.5-25mm.
A SF173, F56, L56 Early-mid 19th-cent. context.
26. Possibly blank flan or late 18th-century halfpenny/tradesman's halfpenny token. Diameter 28.5mm. A SF13, L2 (2M, 108/1002) Unstratified.
27. Unofficial coin-weight for English gold guinea of George III, after 1772.
Obv : S.D./20.6/OR/DwtG/5:6.
Rev : Geo. III/up to the 1st of Jan^y/1772, both with beaded border. The piece has an 18th-century appearance but could have remained in use for a long period. Diameter 21.5mm. A SF104h, F57, L57 Mid-late 18th-cent. context.

1. E.T. Leeds, 'Oxford Tradesmens' Tokens in H.E. Salter (ed.) Surveys and Tokens, (O.H.S. lxxv (1923)), 358-453.

2. Ibid.

COINS, TOKENS, COUNTERS AND COIN-WEIGHTS

28. George III penny, 1797. Diameter 36mm. A SF229, F13, L11 Late 18th-cent. context.
29. George III penny, 1806 or 1807. Diameter 33.5 mm. A SF230, F13, L11 Late 18th-cent. context.
30. George III halfpenny, c. 1806. Diameter 30mm. A SF11 L2 (2M, 108/1006) Unstratified.
31. George III farthing, early 19th century. Diameter 23.5mm. A SF24, L2 (2M 114/1010) Unstratified.
32. George IV halfpenny, 1820-30. Diameter 27.5mm. A SF9, L2 (2M, 108/1006) Unstratified.
33. Napoleon III 5 centimes, 1855. Pierced. Diameter 25mm. A SF40, L2 (2M, 104/1004) Unstratified.
34. Napoleon III 10 centimes, mid 19th century. Diameter 29.5mm. A SF4, F14, L12 Mid-late 19th-cent. context.
35. Victoria halfpenny, 186? Diameter 25.2mm. A SF5, F14, L12 Mid-late 19th-cent. context.
36. ?Victoria halfpenny, after c. 1860. Diameter c. 25mm. A SF6, F14, L12 Mid-late 19th-cent. context.
37. Victoria halfpenny, c. 1860-90. Diameter 25.2mm. A SF7, F14, L12 Mid-late 19th-cent. context.
38. Imitation George III 'Spade' guinea. Bronze gilt. After 1787, up to 1900. Diameter 20mm. A SF2151a, F13, L11 Late 18th-cent. context.

Site B, Greyfriars

39. Nuremberg jetton 'early-mid', 'standard types', c. 1530-40. B X SF18 Unstratified.
40. Jetton, just possibly English made.
Obv. shield with bend or three bendlets.
Rev. simple cross fleury of three strands, similar to French 15th-century types. Resembles some odd 'mid' Nurembergs or copies of them, with ticks for legend but this is thicker - an odd piece. I think it is late: early-mid 16th century. B IV SF39, L5 16th-cent. context.

COINS, TOKENS, COUNTERS AND COIN-WEIGHTS

- 41-42. Nuremberg jettons, Hans Krauwinkel, 1580-1610. B VI SF1, L2 and B X SF20 Unstratified.
43. Silver sixpence ?16th-17th century, possibly Elizabeth I. Diameter 22.5-24mm. B X SF17, Unstratified.
44. Charles I Richmond farthing, 1625-34. Obv. CARO R(EX). Diameter 16-16.5mm. B VI SF2, L1 Unstratified.
45. Charles I Rose farthing, 1636-44. Obv: CAROLVS - crown over crossed sceptres. Initial mark illegible Rev: crowned rose. Diam. 12.5-13.5mm. B X SF16, Unstratified.
46. Oxford City Council farthing token, 1652 or later. Obv: THE.MAYOR.OF - arms of Oxford. Rev: OXFORD. TOKEN - C.O/1652/.R. within cabled circle. Leeds¹ No. 7 (his most frequent type). Diameter 16mm. B X II SF5, Unstratified.
47. William and Mary farthing, 1694. Diameter 23mm. B V SF7, F6, L1. Late 17th-~~cent.~~^e context.
48. George III Irish halfpenny, 1805. Rev: crowned harp. Diameter 27.8mm. B IV SF11, L10 Unstratified.
49. George III halfpenny, 1805-6. B V SF3, L2 Unstratified.
50. George III halfpenny, 1806. Rev : Britannia. Diameter 28.5mm. B V SF14, L2 Unstratified.
51. Coin-weight for George III gold guinea, after 1772². Crown (stamped)/P.W.G./5:8. Rev : plain. Has 19th century appearance. Diameter 21.5mm. B IV SF4, L1 Unstratified (early 19th-cent. material).

1 E.T. Leeds, 'Oxford Tradesmen's Tokens' in H. E. Salter (ed.), Surveys and Tokens (O.H.S. lxxv (1923), 361; 368.

2 C.C. Chamberlain, Guide to Numismatics, (Teach Yourself, 1960), 175-76.

COINS, TOKENS, COUNTERS AND COIN-WEIGHTS

Site W, Westgate

52. Probabiy farthing, Charles II or up to George III, must be after 1672.
Diameter 22mm. W SF5, F45 Mid-late 18th-cent. context.
53. George I farthing, 1717-24. Diameter 21mm. W SF4, F25 Mid 18th-cent. context.
54. George I Irish farthing, 1723. Could have been in circulation until 1800.
Diameter 20.7mm. W SF22, F25 Mid 18th-cent. context.

IV A10 - A14 Blank

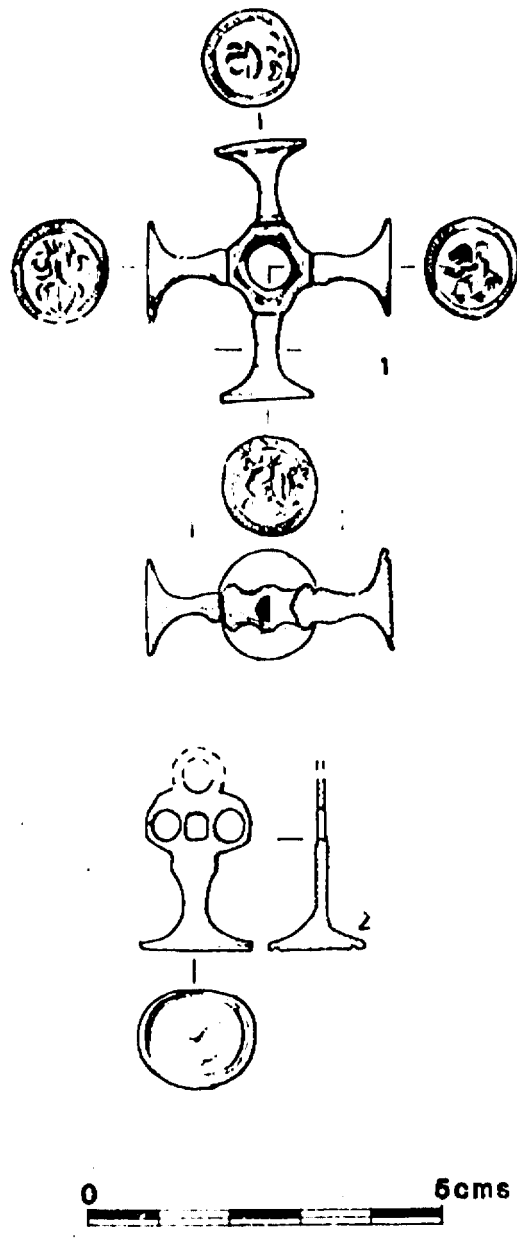

Fig.112 Copper Alloy Seals

IV B1

Figs. 112-22.

Site A : 1-89; Site B : 90-127; Site D: 128-131; Site W: 132-139.

Site A, 31-34 Church St.

1. Multiple seal with four engraved faces on moulded stems joined to a central ring. Each face has a zig-zag border within which are the following devices : i) bird with spread wings, ii) heart pierced by two crossed arrows and surmounted by a crown, iii) fleur-de-lys, iv) ?maple leaf. The manufacture of the seal and the engraving of the matrices are quite crude. The seal was presumably a personal one and the devices are of no armorial significance. Multiple seals of similar type can be seen in Norwich Castle Museum (Accession Nos.76.94(208) and 31.942); another was found at North Tuddenham, Norfolk. Others are held by the Fitzwilliam Museum, Cambridge, and the British Museum¹ but none has a definite provenance or date. A SF2020, F2093, L2015 (=F17) Mid-late 17th-cent. context.
2. Seal with perforated trefoil-shaped handle. The oval matrix is badly corroded but may show a lion mask within a plain border. It was probably a personal, non-heraldic seal.² A SF104g, F57, L57 Mid-late 18th-cent. context.,

1. A.B. Tonnochy, Catalogue of British Seal-Dies in the British Museum, (1952), Nos. 658 and 665; information from Dr. S.M. Margeson (Norwich) and J.G. Poliard (Cambridge).

2. Ibid. Nos.666, 675 and 678.

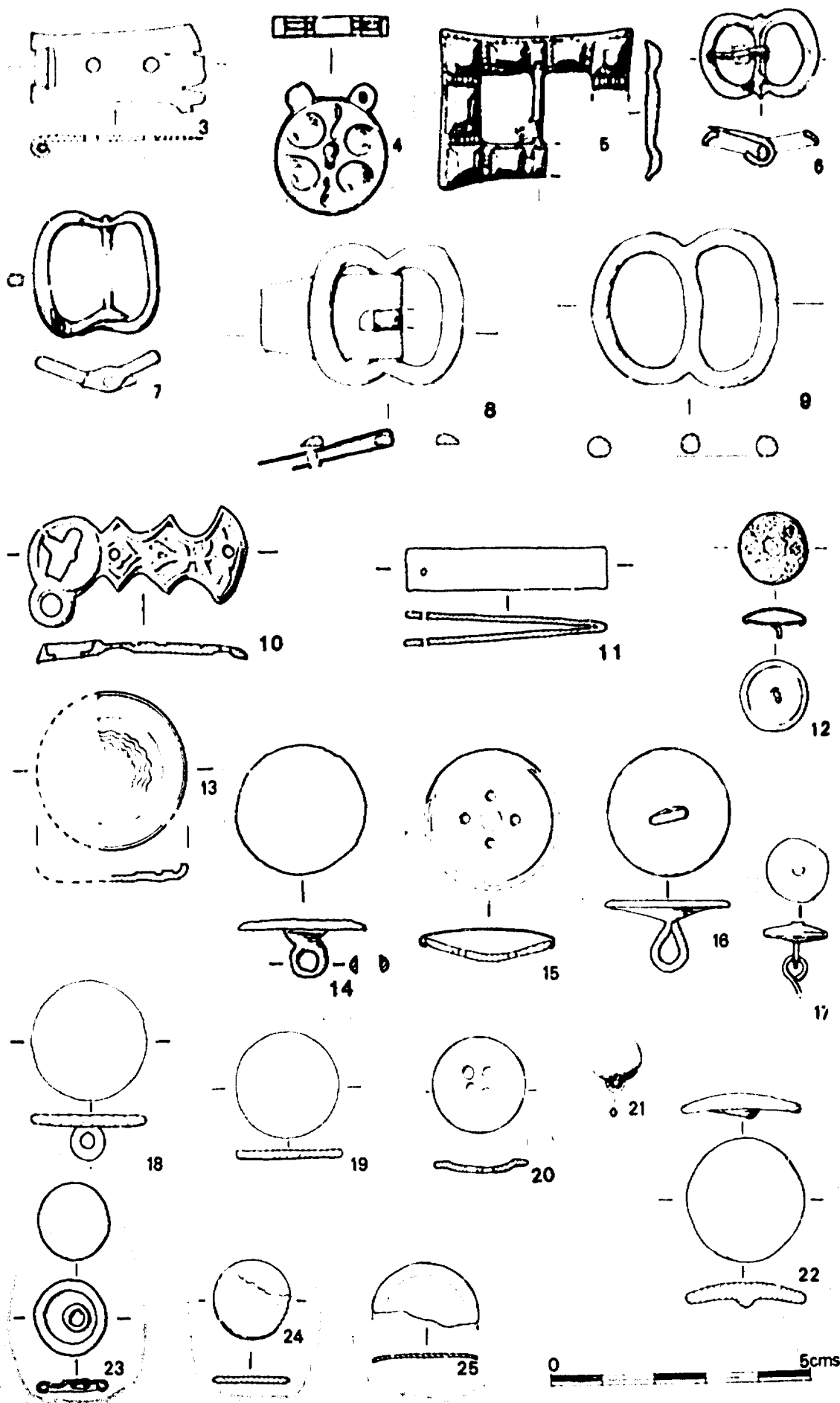

Fig.113 Copper Alloy Objects

COPPER ALLOY AND SILVER OBJECTS

3. Book clasp or hinge, probably related to objects such as No.116 from Site B (Greyfriars), though lacking the characteristic decoration. The bar is made from tightly rolled sheet. A SF73, F1, L102 Mid-late 17th-cent. context.
4. Padlock with lugs for the missing shackle and incised decoration of spirals on the front of the circular case. A SF231, F13, L11 Late 18th-cent. context.
5. Buckle with relief decoration probably imitating gemstones. A SF505, F45, L171 Mid-late 17th-cent. context.
6. Double-looped buckle with the ends of the pin-bar projecting at top and bottom. Both loops are notched to take the point of the pin. A SF58, F52 (= L2) Undated context.
7. Double-looped buckle with frame made from a single strip perforated in the middle and in the overlapping ends. The broken iron pin-bar passes through the perforations. A SF1059, L1279 (= L2) Undated context.
- 8-9. Double-looped buckles. No.8 has riveted buckle plates.
8. A SF2021, F2504, L8 (= F2011) Early 17th-cent. context;
9. A SF2023, F2504, L8 (= F2011) Early 17th-cent. context.
10. Strap fitting with suspension ring and decorated plate; damaged. The cast decoration resembles that on buckles and strap-ends from a late 16th-century feature at Moulsham Street, Chelmsford, Essex.¹
A SF27, L2, (2M, 112/998) Unstratified.
11. Narrow strap-end with single rivet-hole. A SF92, F98, L90 16th-cent. context.
- 12-25. Buttons. No.12 has floral decoration on the upper plate. No.15 has a bone back rebated to take the overlapping copper alloy plate; the space between packed with white paste. No.17 is a pair of linked buttons with white metal plating. No.23 is gilded.
12-13. A SF67, F56, L56 Early-mid 19th cent. context; 14. A SF104c, F57 L57 Mid-late 18th-cent. context; 15-16. A SF180, F57, L57 Mid-late 18th-cent. context; 17. A SF503, F45, L171 Mid-late 17th-cent. context; 18-19. A SF2151, F13, L11 Late 18th-cent. context; 20. A SF62, F72, L82 Mid 19th-cent. context; 21. A SF70, L2 (2M, 114/1008) Unstratified; 22. A SF21₁², L2 (2M, 114/1008) Unstratified; 23. A SF214, L2 (2M, 106/1002) Unstratified; 24. A SF216, L2 (2M, 106/1008) Unstratified; 25. A SF1025, F60, L34 Mid 18th-cent. context.

1. Alison R. Goodall, 'Copper Alloy Objects' in P.J. Drury, Moulsham Street, Chelmsford, forthcoming.

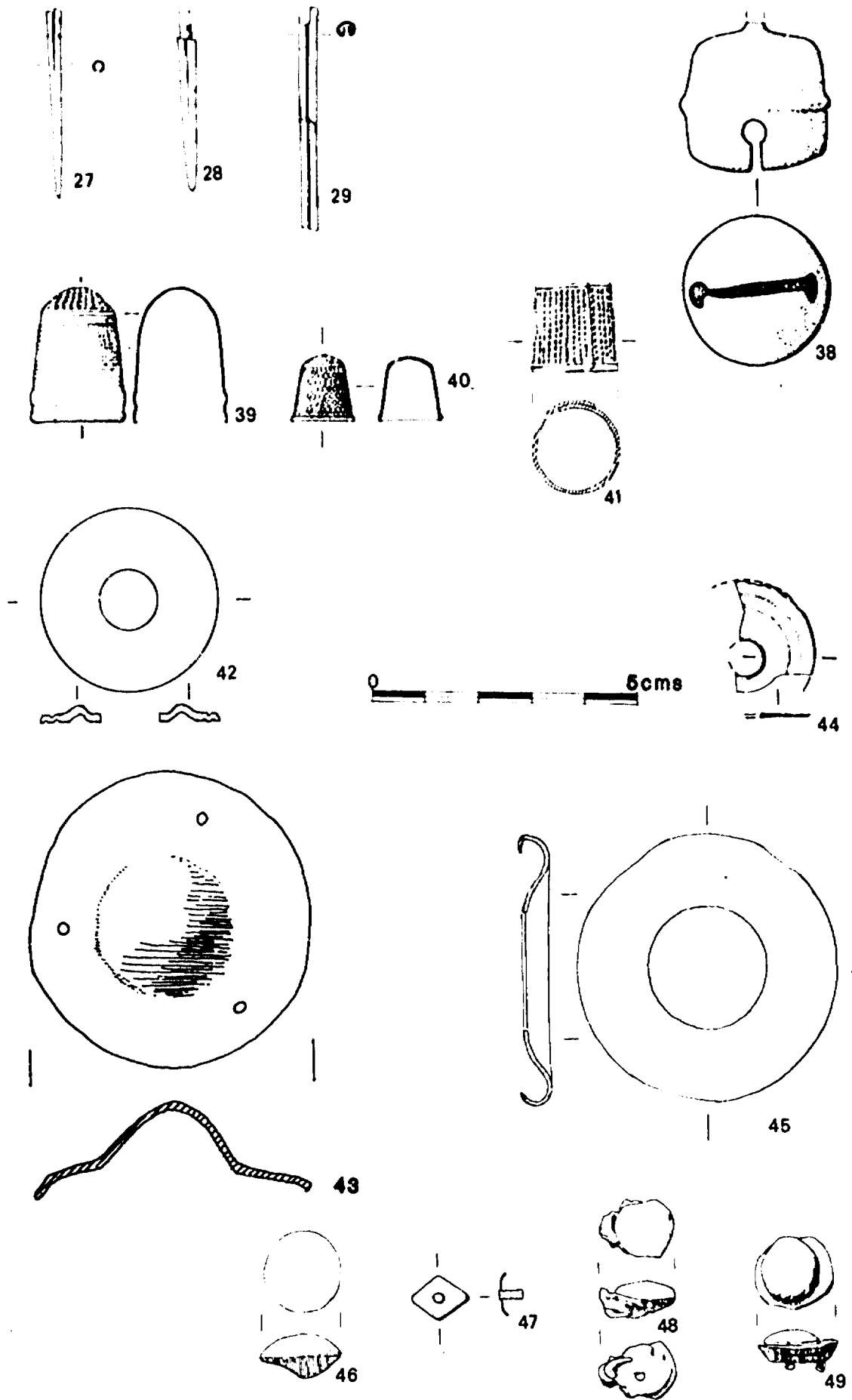

Fig.114 Copper Alloy Objects

COPPER ALLOY AND SILVER OBJECTS

- 26-37. Lace-ends. No.28 retains part of the leather lace. No.27 has two securing pins. Nos. 27-29 are illustrated.
26. A SF97b, F82, L83 Early-mid 17th-cent. context; 27. A SF2007, F2, L2011 Early-mid 17th-cent. context; 28-31. A SF2010, F17, L2012 Mid-late 17th-cent. context; 32. A SF2045, F2504, L3 Late 16th-cent. context; 33. A SF2115, F2531 16th-cent. context; 34. A SF2134, F2531, L1 16th-cent. context; 35. A SF2072, F2, L2029 Undated context; 36. A SF2a, Trial Trench L1 Undated context; 37. A SF1063, L2 (2M,110/998) Unstratified.
38. Bell made from two hemispheres of sheet metal. A SF1244, F1529 Early 17th-cent. context.
- 39-41. Thimbles. No.39 has a lattice arrangement of pits on the top and fine pits on the sides. No.40 must have belonged to a child, while No.41 is an annular tailor's thimble made from sheet metal with the pits aligned vertically.
39. A SF2257, F17, L2010 + L15 Mid-late 17th-cent. context;
40. A SF228, F13, L11 Late 18th-cent. context;
41. A SF1008, L2 (0.5m, 111.5/1010.5) Unstratified.
- Pins. Almost all the 83 complete examples have heads made from coils of wire of the same thickness as the shanks and stamped to a spherical shape. One large pin, length 52mm, has a globular head and another has a discoid head made from fine wire. Several of the pins have evidence of white metal plating.
42. Annular mount, possibly a knife handle plate. A SF67, F56, L56 Early-mid 19th-cent. context.
43. Circular mount with almost conical boss in centre; three pin-holes in flange. A SF1003, F1001, L1002 Mid 17th-cent. context.
44. Incomplete disc with central perforation and concentric grooves; broken through outer groove. A SF2011, F17, L2012 Mid-late 17th-cent. context.
45. Annular object of sheet metal with the outer edge rolled under. A SF2151, F13, L11 Late 18th-cent. context.
46. Stud. A SF1024, F60, L34 Mid 18th-cent. context.
47. Lozenge-shaped mount with central rivet. A SF2060, F2, L2029 Undated context.
- 48-49. Two studs or buttons with loops or pairs of shanks passing through leather. A SF55, F52 (= L2) Undated context.

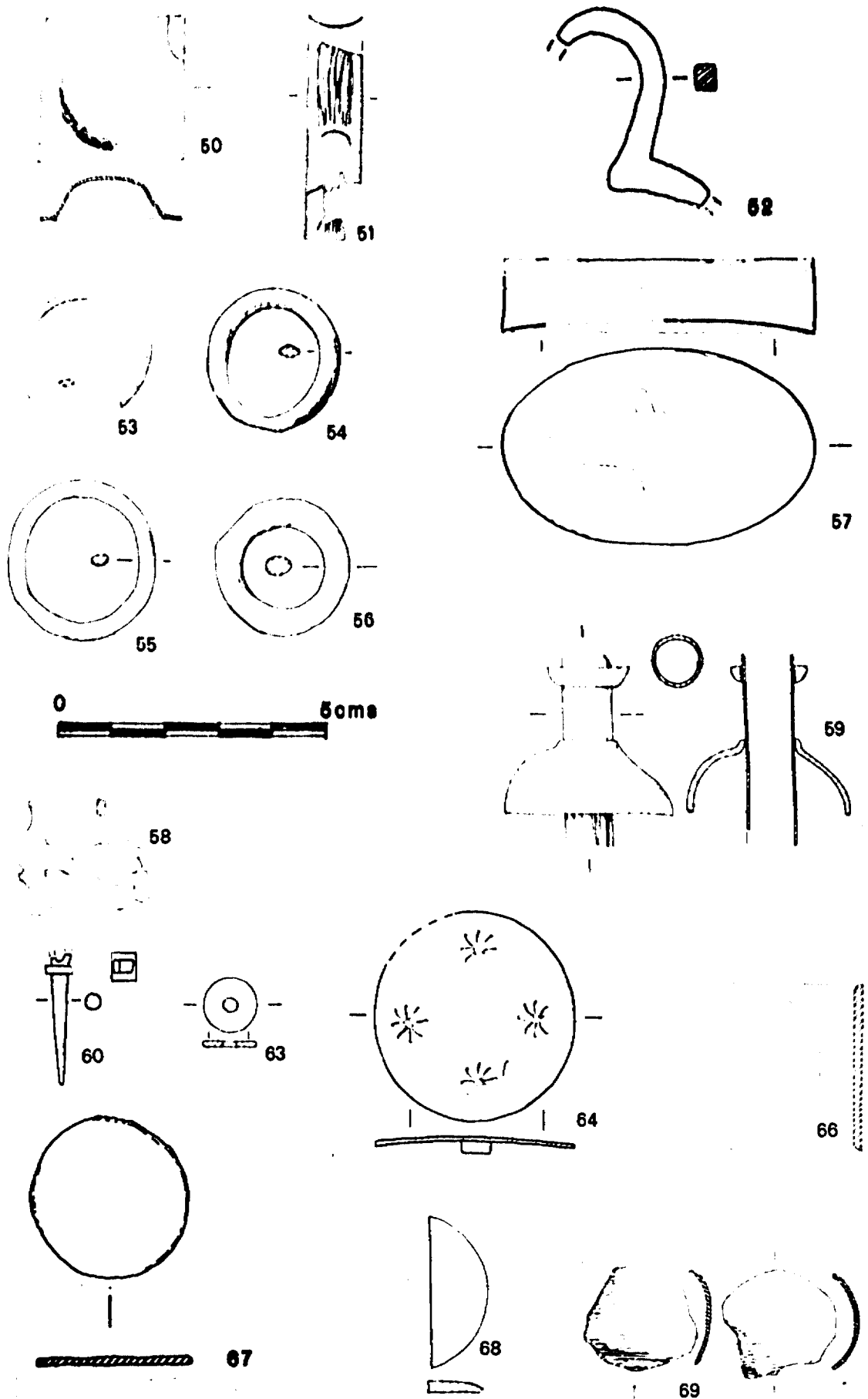

Fig.115 Copper Alloy Objects

COPPER ALLOY AND SILVER OBJECTS

50. Rectangular plate with domed boss in centre; no means of attachment. Cf. No.122 from Site B (Greyfriars).
A SF1112, L2 (2M, 110/996) Unstratified.
51. Incomplete strip with repoussé disc and incised texturing.
A SF2005, F17, L2010 Mid-late 17th-cent. context.
52. Incomplete object. A SF97b, F82, L83 Early-mid 17th-cent. context.
- 53-56. Rings, probably from curtains.
53. A SF168, F1, L102 Mid-late 17th-cent. context;
54. A SF1028, F60, L34 Mid 18th-cent. context;
55. A SF218, L1 Unstratified;
56. A SF1115, L2 (2M, 110/998) Unstratified.
57. Base of an oval box. Another box came from Civil War and later deposits at Sandal Castle, West Yorkshire.¹ They would have been used for snuff or tobacco. A SF1061, L39 Undated context. See also M VI F4.
58. Object of unknown use. A SF1025, F60, L34 Mid 18th-cent. context.
59. Cylinder of sheet metal with two convex collars, one much larger than the other, attached to it. Probably part of a simple candlestick.
A SF1086, L2 (2M, 104/1002) Unstratified.
60. Brooch pin. A SF1106, L2 (104/1012) Unstratified.
- 61-63. Perforated discs or washers. Nos. 61 and 62 are not illustrated.
61. A SF65, F71, L44 Early 17th-cent. context;
62. A SF1116, L2 (2M, 110/1000) Unstratified;
63. A SF2151, F13, L11 Late 18th-cent. context.
64. Possibly a large button although no eye is visible. Flower design on upper surface. A SF111, F54, L54 Early-mid 19th-cent. context.
65. Corroded disc with fabric, hairs, etc. adhering to it. Not illustrated
A SF1021, F60, L34 Mid 18th-cent. context.
- 66-68. Discs and a fragment of disc. 66. A SF46/4, L70 16th-cent. context
67. A SF46/5, L70 16th-cent. context; 68. A SF2151, F13, L11 Late 18th-cent. context.
69. Two convex discs possibly originally joining along their edges.
A SF 1024, F60, L34 Mid 18th-cent. context.

1. Alison R. Goodall, 'Copper Alloy Objects' in P. Mayes and L.A.S. Butler, Sandal Castle Excavations 1964-1973, (1983).

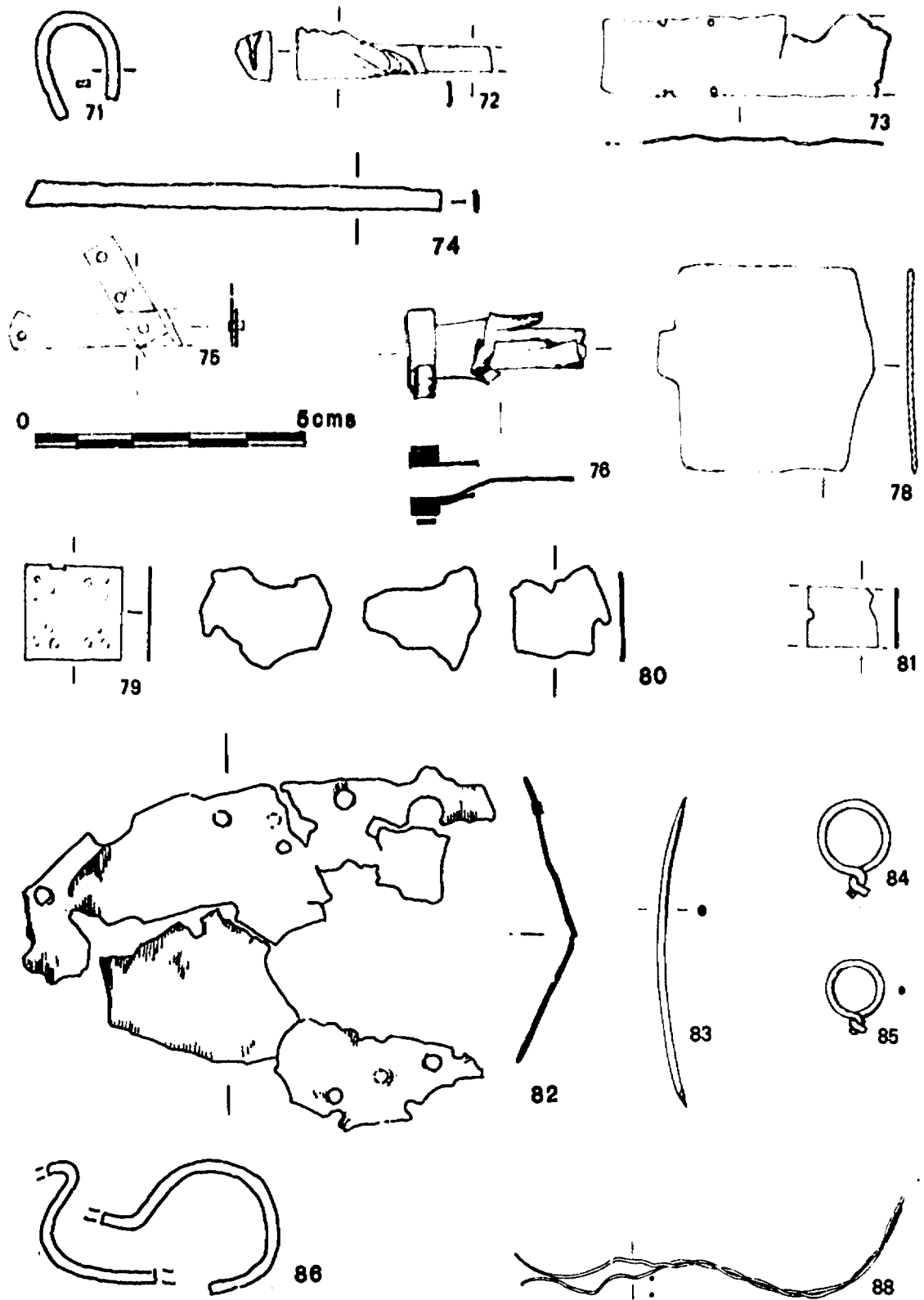

Fig.116 Copper Alloy Objects

COPPER ALLOY AND SILVER OBJECTS

- 70-75. Pieces of strip. No.72 appears to have one end embedded in wood. No.75 is two strips riveted together, No.70 is not illustrated.
70. A SF116, F1, L102 Mid-late 17th-cent. context;
71. A SF172, F45, L48 Mid-late 17th-cent. context;
72. A SF180, F57, L57 Mid-late 18th-cent. context;
73. A SF205, F11, L2018 Early-mid 17th-cent. context;
74. A SF2046, F19, L2022 (= F17) Mid-late 17th-cent. context;
75. A SF2058, F1001, L2002 Mid 17th-cent. context.
76. Distorted cylinder with strip coiled round one end.
A SF2037, L2 (2M, 100/1000) Unstratified.
77. Fragment probably from a vessel rim. Not illustrated. A SF194, F41, L91
16th-cent. context
- 78-82. Fragments of sheet metal. No.79 is decorated.
78. A SF1154, F1529, L1 Early 17th-cent. context;
79. A SF2004, F17, L2010 Mid-late 17th-cent. context;
80. A SF2008, F17, L2012 Mid-late 17th-cent. context;
81. A SF2011, F17, L2012 Mid-late 17th-cent. context;
82. A SF2141, F2531, L2 16th-cent. context.
83. Rod pointed at both ends. A SF2003, F17, L2010 Mid-late 17th-cent.
context.
- 84-85. Twist-loops of wire.
84. A SF2058, L2002 Undated context; 85. A SF1124, L2 (2M, 110/996)
Unstratified.
- 86-88. Lengths of wire, c.1.5mm, c.1.3mm and c.0.5mm in thickness respectively.
The thicknesses do not suggest that the wire was for use in pin making.
No.87 is not illustrated.
86. A SF2002, F17, L2010 Mid-late 17th-cent. context;
87. A SF2067, L2007 (2M, 102/1002) Undated context;
88. A SF1099, L2 (2M, 110/1000) Unstratified.

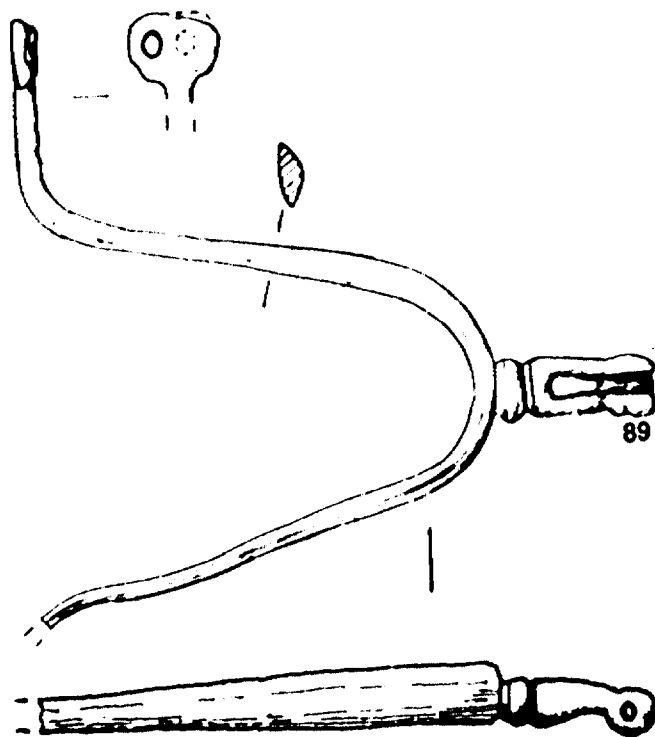

Fig.117 Copper Alloy Spur

COPPER ALLOY AND SILVER OBJECTS

89. Blanche Ellis writes:- Copper alloy rowel spur of very slender proportions. The straight sides of D-section but their outer surfaces slightly faceted by the suggestion of two horizontal lines. The sides taper towards the terminals, one of which is a small, evenly set figure-8, the other missing. The complete side is now bent outwards. The small round neck has a moulding next to its junction with the sides. It is fairly straight but the entire rowel box droops slightly and tapers towards the round rowel bosses; the top surfaces of the latter have become flattened by abrasion. Traces of a tiny vertical ridge remain between each rowel boss and the rest of the neck. Remains of the middle of the rowel. The rowel pin may have been iron (there is a minute suggestion of rust but no response to a magnet). Length overall if bent side were straightened, 106mm. Length of neck, 22mm. Second half of the 17th-century, or early 18th-century.

A SF2084, L2 (2M, 100/1014) Unstratified.

Note: Three buckles of medieval type came from 16th-and early 17th-century contexts and the site also yielded a number of pins of medieval type.

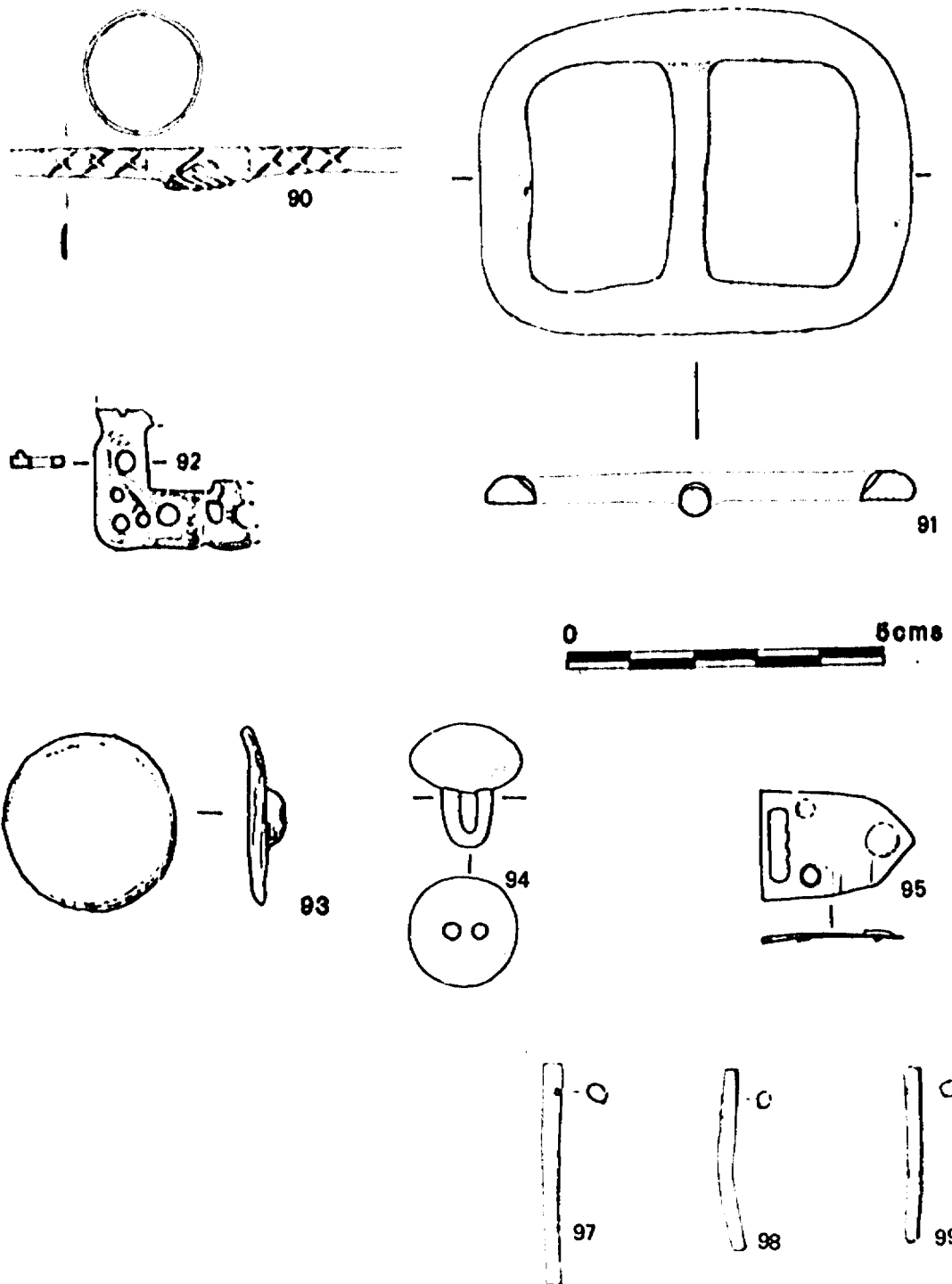

Fig.118 Copper Alloy and Silver Objects

COPPER ALLOY AND SILVER OBJECTS

Site B, Greyfriars

Silver

90. 'Fede' ring with clasped hands on the bezel and three incised crosses on each side. Rings of this type signified marriage or betrothal and were current from the Roman to the post-medieval period.¹ B IV, SF12, L12 Undated context.

Copper Alloy

91. Heavy buckles; the pin bar, set back from the frame, has a constriction around which an iron pin would have swivelled: the side of the frame has a recess to take the pin point.
B VI SF19, F3 Mid 18th-cent. context.
92. Openwork decorated shoe-buckle fragment. B X SF27, F26. Mid 18th-cent. context + intrusive 19th-cent. material.
- 93- Buttons. No.93 has traces of corrosion on the back from an iron
94. loop.
93. B IV SF63, L20 Unstratified; 94. B IV SF95, F101 Mid-late 17th-cent. context.
95. Clasp. A similar, but larger and more angular example comes from Cambridge,² and is dated to the second half of the 17th century.
B VI SF34, L13 Late 17th-cent. context.
- 96- Lace-ends. No.98 has two securing pins, the others only one; the
99. end of the thong remains inside Nos. 97 and 99. No.96 is not illustrated.
96. B V SF9, L7 Undated context; 97. B VI SF6, F2 16th-cent. context; 98. B VI SF8, F2 16th-cent. context;
99. B VI SF32, L12 16th-cent. context.

1. British Museum, A Guide to the Medieval Antiquities and Objects of Later Date, (1924), 150.

2. P.V. Addyman and M. Biddle, 'Medieval Cambridge: Recent Finds and Excavations', Proceedings of the Cambridge Antiquary Society, lviii (1965), 127; Fig. 21, No.4.

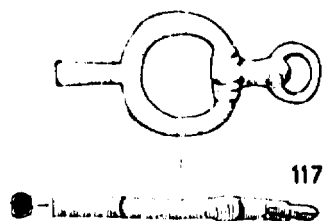
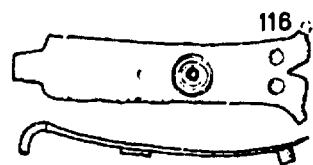
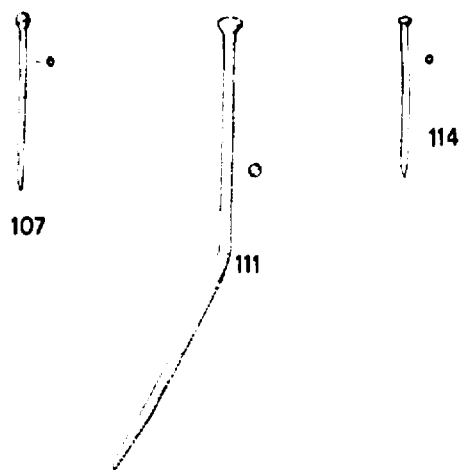
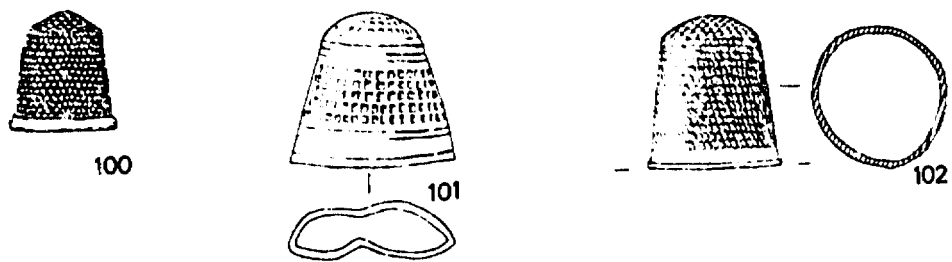

Fig.119 Copper Alloy Objects

COPPER ALLOY AND SILVER OBJECTS

- 100- Thimbles. Nos.100 and 101 have tapering sides; No.100 has a
102. conical top and a ridge round the bottom edge. No.102 has almost
vertical sides and a slight ridge at the bottom edge.
100. B IV SF35, F44 Early-mid 18th-cent. context; 101. B VI SF17,
L1 Unstratified; 102. B X SF26, F26 Mid 18th-cent. context (-
intrusive 19th-cent. material)
- 103- Pins, ranging in length from 24 to 68+mm. Seven have evidence of
115. white metal plating. No.111 has a flat head and No.114 has a
single-turn coiled wire head; eight have the more common two-turn
coiled-wire head and most of them have been stamped to a spherical
shape; the remaining pins are incomplete. Not illustrated except
Nos 107, 111, 114.
103. B VI SF25, L3 Medieval context; 104. B VI SF24, L3 Medieval
context; 105. B IV SF27, L17 Early 17th-cent. context;
106. B V SF19, F2 L1 Early-mid 18th-cent. context;
107-109. B VI SF11, F3 Mid 18th-cent. context;
110. B IV SF9, F4 L1 Undated context; 111. B IV SF61, L1
Unstratified(early 19th-cent. material); 112. B IV SF6, L1
Unstratified (early 19th-cent. material);
113. B VI SF5, L2 Unstratified; 114. B VI SF10, L2 Unstratified;
115. B VI SF9, L2 Unstratified.
116. Book clasp with two copper-alloy rivets 'in situ' at the splayed
end; this end is incomplete. Decorated with a deeply impressed dot
and two shallower concentric circles. On the underside are the
remains of a strap, as on an example from Basing House, Hampshire,¹
possibly dating from before 1531. Another example, from
Southampton,² is dated to c. 1630-40. BXXXIII SF5, F10 Early-mid
17th-cent. context.
117. Watch key with hollow, slightly squared end, annular bow and
suspension loop. B IV SF8, L1 Unstratified (early 19th-cent.
material).

1. S. Moorhouse, 'Finds from Basing House, Hampshire (c. 1540-1645):
Part Two', Post-Medieval Archaeology, v (1971), 59; Fig. 25,
No. 162.

2. Y. Harvey in C. Platt, R. Coleman-Smith et al., Excavations in
Medieval Southampton, ii, The finds, (1975), 268; Fig. 245,
No. 1881.

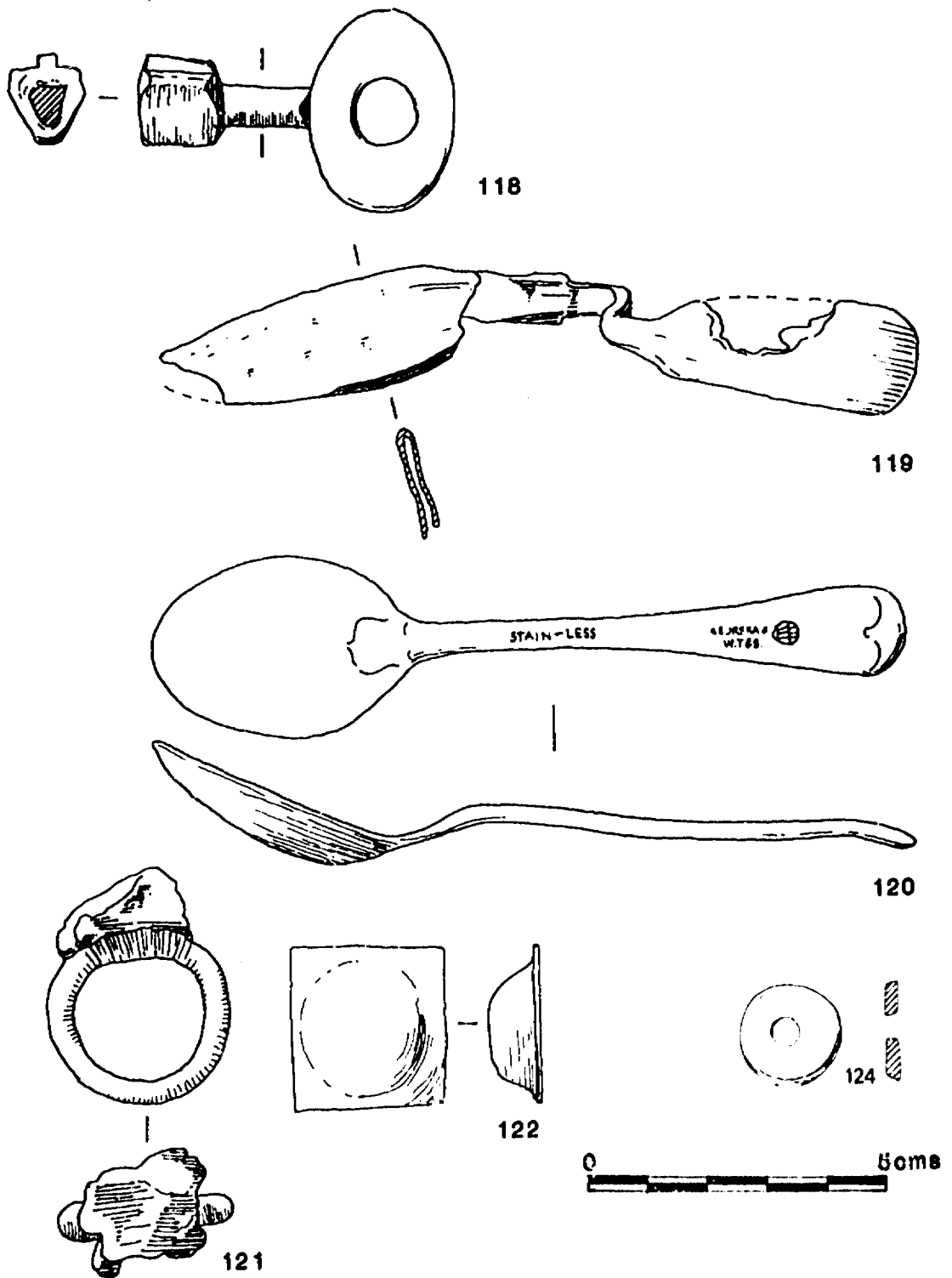

Fig. 120 Copper Alloy Objects

COPPER ALLOY AND SILVER OBJECTS

118. Clock key with a hollow triangular end, having a flange on one side, and a perforated oval bow. Possibly 19th-century.
B XXVIII SF1, L103. Undated context.
- 119-120. Spoons. No.119 has white metal plating and is now broken and distorted; No.120, also with white metal plating, is inscribed on the back of the handle with 'STAIN-LESS' and the manufacturer's mark.
119. B IV SF62, L1 Unstratified (early 19th-cent. material);
120. B IV SF70, L10 Unstratified.
121. Oval swivel-ring with remains of iron attachment. B IV SF1, L1 Unstratified (early 19th-cent. material).
122. Domed boss with an approximately square flange. B VI SF38, L12 16th-cent. context.
123. Ring, diameter 34.5mm (not illustrated). B VI SF49, F18 Late 17th-cent. context.
124. Pierced disc. B X SF12, F27 Mid-late 18th-cent. context (+ intrusive 19th-cent. material).
- 125-126. Discs (not illustrated).
125. B VII SF17, F5 Mid 19th-cent. context, diameter 28mm;
126. B V SF11, L1 Unstratified, diameter 21mm.

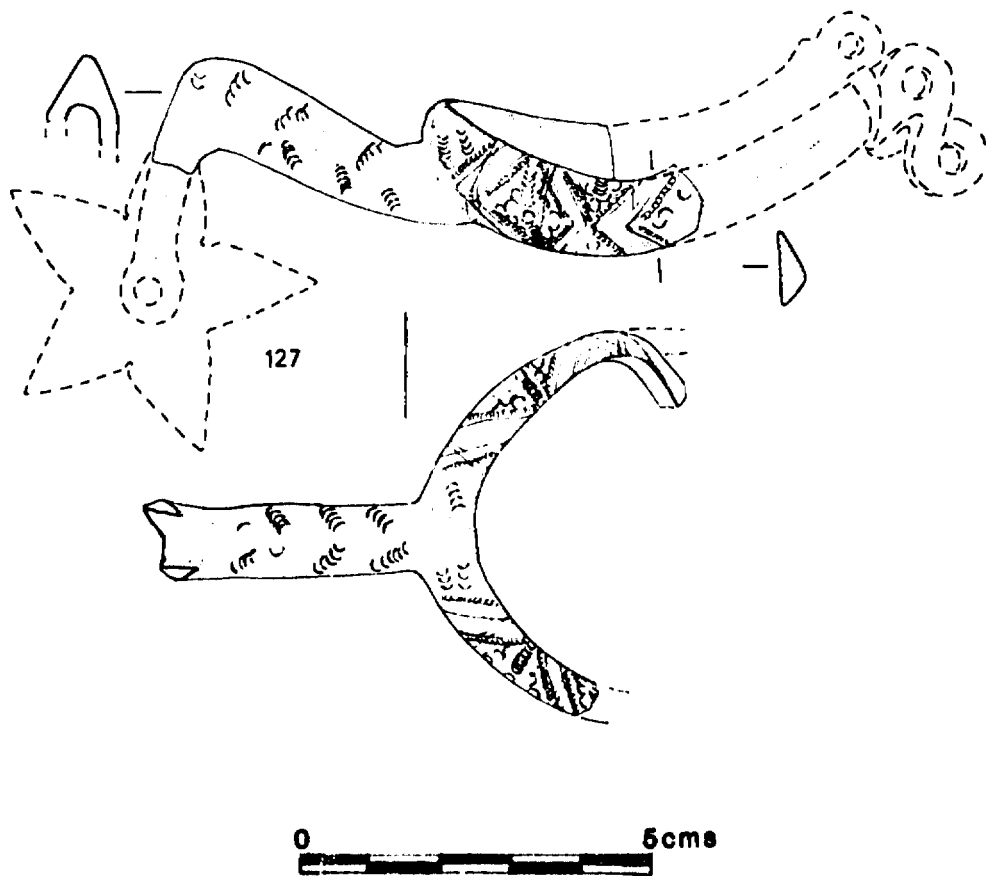

Fig.121 Copper Alloy Spur

COPPER ALLOY AND SILVER OBJECTS

127. Spur. Blanche Ellis writes :- Fragment of a copper alloy rowel spur comprising half the neck and stumps of both sides. The sides, of triangular section, are decorated with incised lines forming diamond-shaped compartments containing large and small punched circles and half circles. This is a version of the stylised vine and trellis pattern popular for the decoration of 17th-century English spurs. The diamond section neck rises behind the heel then commences a downward bend at the commencement of the rowel box division, where the rest of the neck has been broken away. It is decorated with diagonal bands of punched half circles. Considerable amounts of gilding remain. The sides also have narrow vertical strips of ?silver plate which appear to outline alternate even sections of gilded and unglided surface, unrelated to the incised pattern. English, c. 1630. Overall length of fragment 81mm. B III SF4, L2 Early-mid 19th-cent. context.

An almost identical copper alloy spur was found in 1969 at Sandal Castle, Yorkshire (unstratified, courtyard), and is now in the Wakefield Museum.¹ It retains both its plain figure-8 terminals supported by a small step at the end of each side. Contemporary copper alloy spurs with punched and incised variations of stylised vine patterns include a fragment from Bolingbroke Castle.²

Two further specimens on permanent loan to the Tower of London Armouries are British Museum AL 116/481, and AL 116/408 (contemporary straight-sided spur with similar pattern to Oxford, Greyfriars spur).

The reconstruction drawing is based on a spur of the same group in a private collection.

-
1. B. Ellis in P. Mayes and L.A.S. Butler, Sandal Castle Excavations 1964-1973, (1983), No.8.
 2. P. Drewett, 'The Excavations of the Great Hall at Bolingbroke Castle, Lincolnshire, 1973', Post-Medieval Archaeology, x (1976), 30; Fig.15, No.54; also Footnote 41 which mentions others.

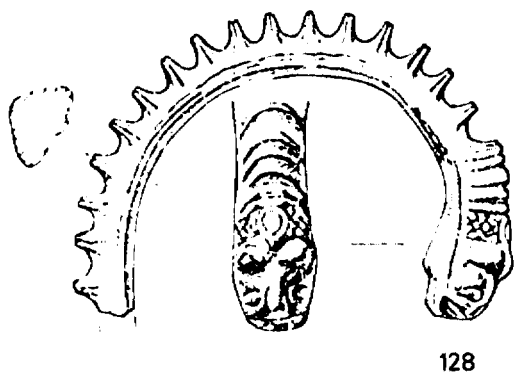

128



129



130



131

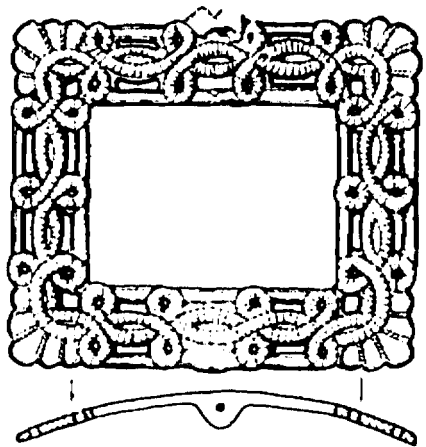

132

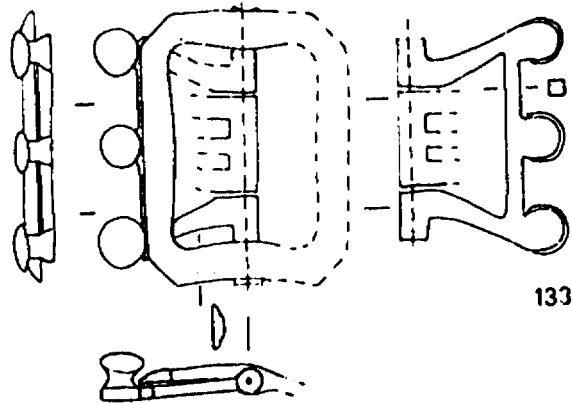

133

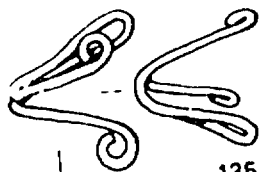

135



136

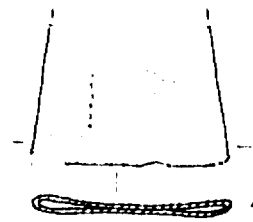

137

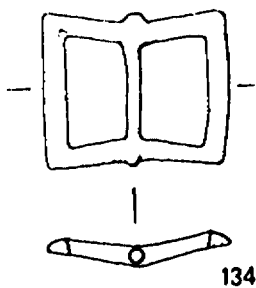

134

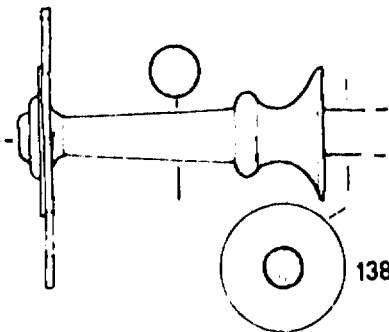
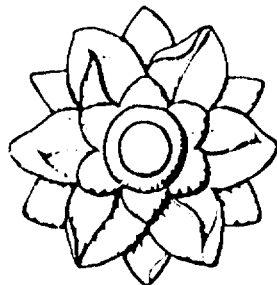

138

Fig.122 Copper Alloy Objects

IV C7

COPPER ALLOY AND SILVER OBJECTS

Site D, Littlegate

128. Part of a penannular bracelet of yellow metal with an animal's head terminal. The casting and finishing are poor. D SF73. Unstratified.
- 129-131. Pins with coiled-wire heads; No.130 has white metal plating.
129. D I SF4, F5 16th-cent. context;
130. D I SF3, L3 Unstratified (Late 18th-cent. material);
131. D I SF9, L3 Unstratified (Late 18th-cent. material).

Site W, Westgate

132. Rectangular ornamental shoe-buckle frame; iron pin assemblage missing. W SF11, F7, L1 Mid 18th-cent. context.
133. Part of another shoe-buckle with three button-like projections. The central pivoting tongue section with three bars is broken. W SF94, F45 Mid-late 18th-cent. context.
134. Double-looped buckle frame. W SF65, F102 Unstratified.
- 135-6. Wire dress-hook with fragment of another. W SF16, F7, L1 Mid 18th-cent. context.
137. Distorted thimble lacking top. W SF12, F7, L1 Mid 18th-cent. context.
138. Ornamental furniture handle. W SF14, F7, L1 Mid 18th-cent. context.
139. Hexagonal sectioned ring; diameter 22.5mm (not illustrated). W SF13, F7, L1 Mid 18th-cent. context.
140. Pin with coiled and stamped head, length 25mm. (not illustrated). W SF20, F22. Early-mid 18th-cent. context.

IV C9 - C10 Blank

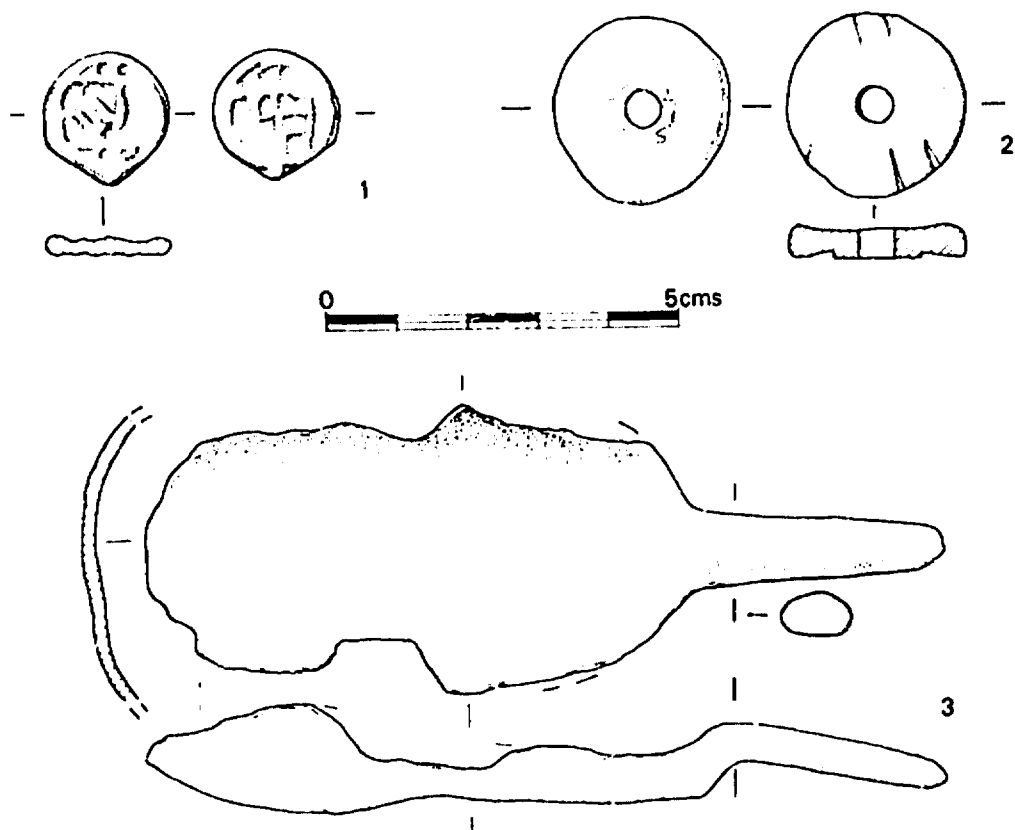

Fig.123 Lead and Lead Alloy Objects

LEAD AND LEAD ALLOY OBJECTS BY GEOFF EGAN, ALISON R. GOODALL AND GWYNNE OAKLEY.

Figs. 123-24

Site A : 1-7; Site B : 8-16; Site D : 17; Site W : 18.

Site A, 31-34 Church St by Geoff Egan.

Not illustrated, except Nos.1-3.

1. Merchant's token? For description see Coins, Tokens, Counters and Coin-weights No.11. A SF1029, F60, L34 Mid 18th-cent. context.
2. Disc with hole slightly off-centre, worn. Weight 19.6gm. A SF516, F45, L171 Mid-late 17th-cent. context.
3. Alloy spoon: large elongated bowl with fragment of handle. A SF178, F57, L57 Mid-late 18th-cent. context.
4. Alloy spoon: fragment of handle and bowl. A SF104f, F57, L57 Mid-late 18th-cent. context.
5. Setting for iron fitting in stonework: for a straight, four-sided bar with an arrow-shaped terminal. Width 20mm, length 110mm+ A SF2050, L2002 Undated context.
6. Irregular offcut. A SF100, F98, L90 16th-cent. context.
7. Solidified molten runnel. A SF113, F44, L47 Late 17th-cent. context.

A fragment of medieval lead stylus was found in A F15, L13 Undated context.

0 5cms

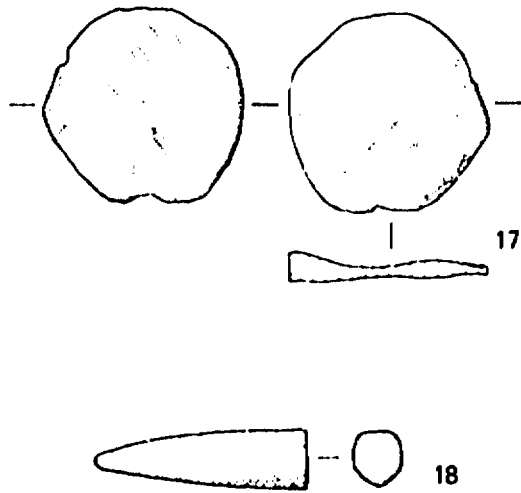

Fig.124 Lead and Lead Alloy Objects

LEAD AND LEAD ALLOY OBJECTS

Site B, Greyfriars by Alison Goodall and Gwynne Oakley.

Not illustrated

- 8-15. Fragments of H-section window pane. No. 9 was very narrow and torn (and possibly residual medieval). Nos. 10, 11, 13 and 14 had raised outer ribs; No. 13 was torn along the central web and partly remelted and No. 11 had been embedded in mortar. Nos. 8 and 12 were wide and both faces of the web in No. 12 were ridged across its width, indicating a post-medieval date.
8. B IV SF6, L1 Unstratified (early 19th-cent. material);
9. B IV SF20, F43 16th-cent. context; 10. B V SF2, L1 Unstratified; 11. B VI SF27, F21 Late 17th-cent. context;
12. B IX SF6, F11 Late 17th-cent. context; 13. B VI SF23, L13;
14. B IV SF32, L4; 15. B IV SF56, L4. Undated context.
16. Irregular rod with once molten end. BII SF25, L1 Unstratified.
Six pieces of lead shot (five c. 2.55mm. in diameter and one 4.5mm) were found wedged inside a glass bottle c. 1740-60. B X SF5, F26 Mid 18th-cent. context (+ intrusive 19th-cent. material).

Site D, Littlegate by Alison Goodall

17. Roughly cut disc, 3mm thick, with incised grooves on both surfaces. Weight 17.8gm. D I SF64, F1/2 16th-cent. context.

Site W, Westgate by Gwynne Oakley.

18. Bullet with pointed nose, roughly cylindrical body and flat base. Weight 11.1gm, diameter 7-8mm. length 30mm. W SF17, F25 Mid 18th-cent. context.

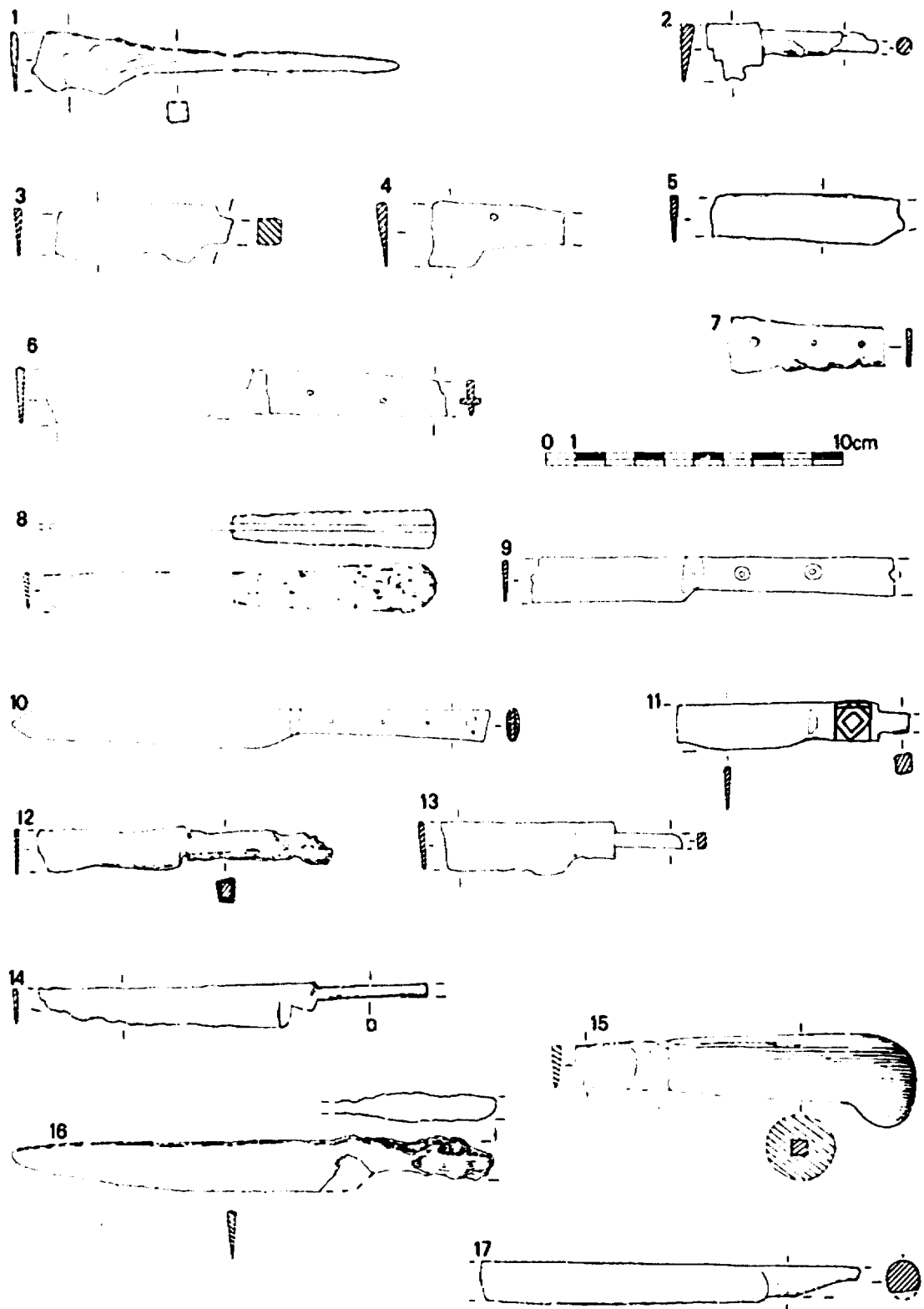

Fig.125 Iron Knives

IRON OBJECTS BY IAN H. GOODALL, SPURS BY BLANCHE ELLIS

Figs. 125-33

Site A : 1-86; Site B : 87-111; Site W : 112-117.

Site A, 31-34 Church St.

- 1-3. Whittle tang knives, two with wood graining on the tang.
1. A SF641, F41, L91 16th-cent. context;
2. A SF636, F17, L15 Mid-late 17th-cent. context;
3. A SF1073, L2 (2M, 110/1000) Unstratified.
- 4-10. Scale tang knives, Nos.4-7 the least complete. No.7, like a knife from St. Neots,¹ has overall non-ferrous brazing metal on the tang. No.8 has an antler handle with iron rivets, see Bone and Ivory Objects No.13. No.9 has copper alloy rivets and decorative washers in the tang as well as riveted shoulder plates. No.10 has a broken wooden handle with iron rivets, soldered non-ferrous shoulder plates and a sharpened blade.
4. A SF2206, F2531 16th-cent. context; 5. A SF2203, F2531 16th-cent. context; 6. A SF1310, F2504, L8 (= F2011) Early 17th-cent. context; 7. A SF656, F71, L44 Early 17th-cent. context; 8. A SF79, F71, L44 Early 17th-cent. context; 9. A SF662, F82, L83 Early-mid 17th-cent. context; 10. A SF96, F82, L83 Early-mid 17th-cent. context.
- 11-15. Whittle tang knives with bolsters, No.11 exceptional in having the bolster inlaid with wire in a geometrical pattern.*
11. A SF1277, F1003, L1010 (= F1023) 17th-cent. context; 12. A SF1150, F1023, L1135 Mid 17th-cent. context (+ some 17th-cent. material); 13. A SF666, F1, L102 Mid-late 17th-cent. context; 14. A SF225, L2 (2M, 116/1010) Unstratified; 15. A SF1001, L2 (2M, 108/1012) Unstratified.
- 16-17 Knives with long bolsters, tangs lost.
16. A SF63, F41, L91 16th-cent. context; 17. A SF1275, F1003, L1027 (= F1023) 17th-cent. context.

1. L. Biek in P.V. Addyman and J. Marjoram, 'An Eighteenth Century Mansion, a Fishpond and Post-Medieval Finds from St. Neots, Huntingdonshire', Post-Medieval Archaeology, vi (1972), 92; Fig.41, No.24.

* No.15 has an ivory handle, see Bone and Ivory Objects No.9.

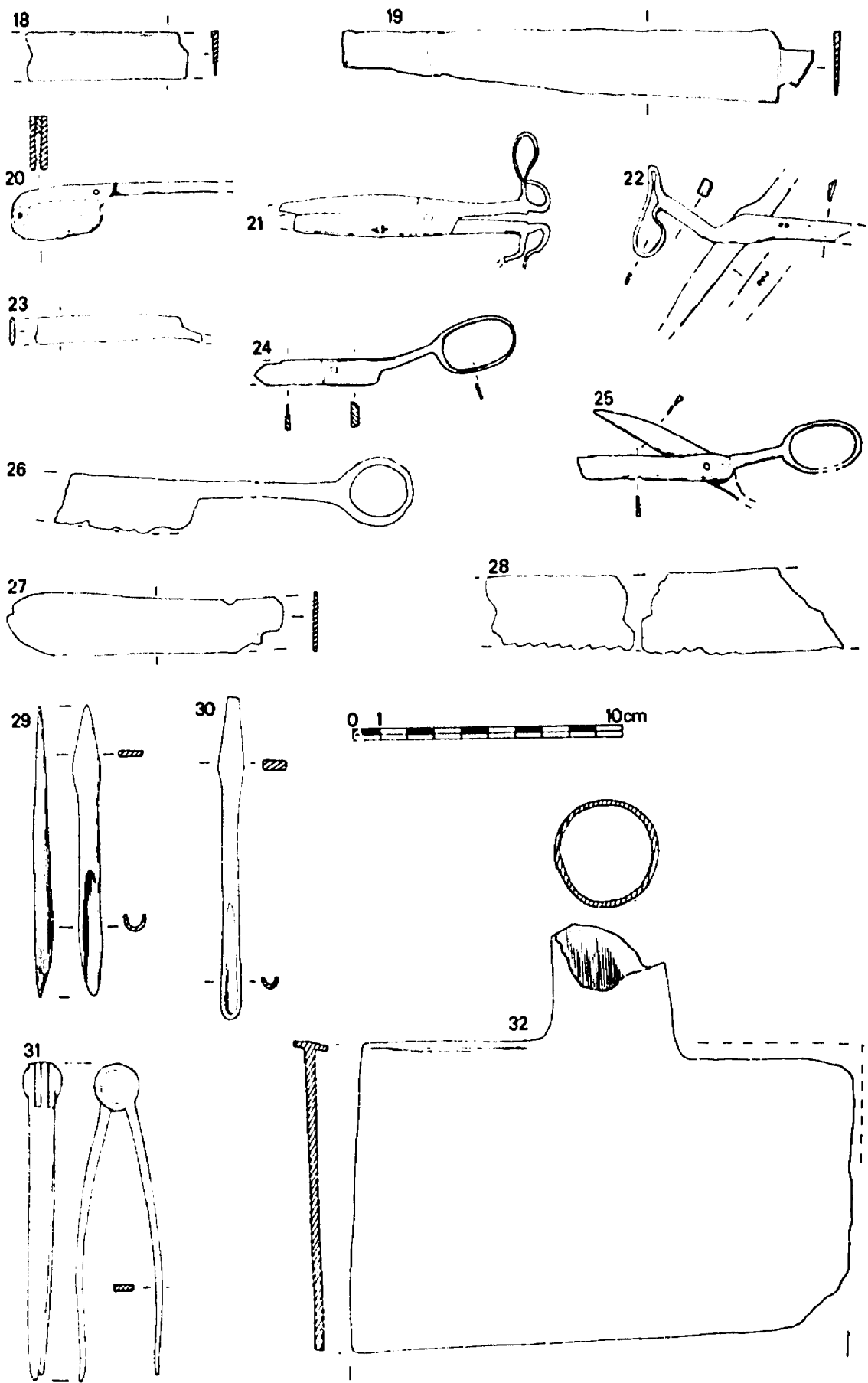

Fig.126 Iron Objects

IRON OBJECTS

- 18-19 Knife blade fragments.
18. A SF1292, F1023, L1122 Mid 17th-cent. context (+ some 17th-cent. material); 19. A SF625, F17, L2012. Mid-late 17th-cent. context.
20. Part of handle from folding knife. A SF650, F56, L56 Early-mid 19th-cent. context.
- 21-26 Scissors, variously incomplete. Two have marks struck on each blade.
21. A SF509, F45, L171 Mid-late 17th-cent. context;
22. A SF169, F1, L102 Mid-late 17th-cent. context;
23. A SF632, F17, L2010 Mid-late 17th-cent. context;
24. A SF1280, F 1005, L1048 Undated context;
25. A SF645, F54, L54 Early-mid 19th-cent. context;
26. A SF1009, L2 (2M, 111.2/1010.9). Unstratified.
27. Spoon handle terminal, similar to a late medieval example from Broughton Lincs.¹ and one of probably mid 16th-century date from Caldecote, Herts.² A SF634, F17, L15 Mid-late 17th-cent. context.
28. Saw blade fragment. A SF626, F17, L2012 Mid-late 17th-cent. context.
29. Gouge bit. A SF1276, F1003, L1010 (= F1023) 17th-cent. context.
30. Spoon bit. A SF120, L2 (2M, 116/998) Unstratified.
31. Dividers, A SF1149, F1023, L1135 Mid 17th-cent. context (+ some 17th-cent. material).
32. Incomplete spade blade with iron socket. A SF2250, F2005, L2021. Early 19th-cent. context.

1 Ian H. Goodall in Stephen Moorhouse, 'A Late Medieval Domestic Rubbish Deposit from Broughton, Lincolnshire', Lincolnshire History and Archaeology, ix (1974), 11; Fig.3, No.25.

2 Excavated by Guy Beresford.

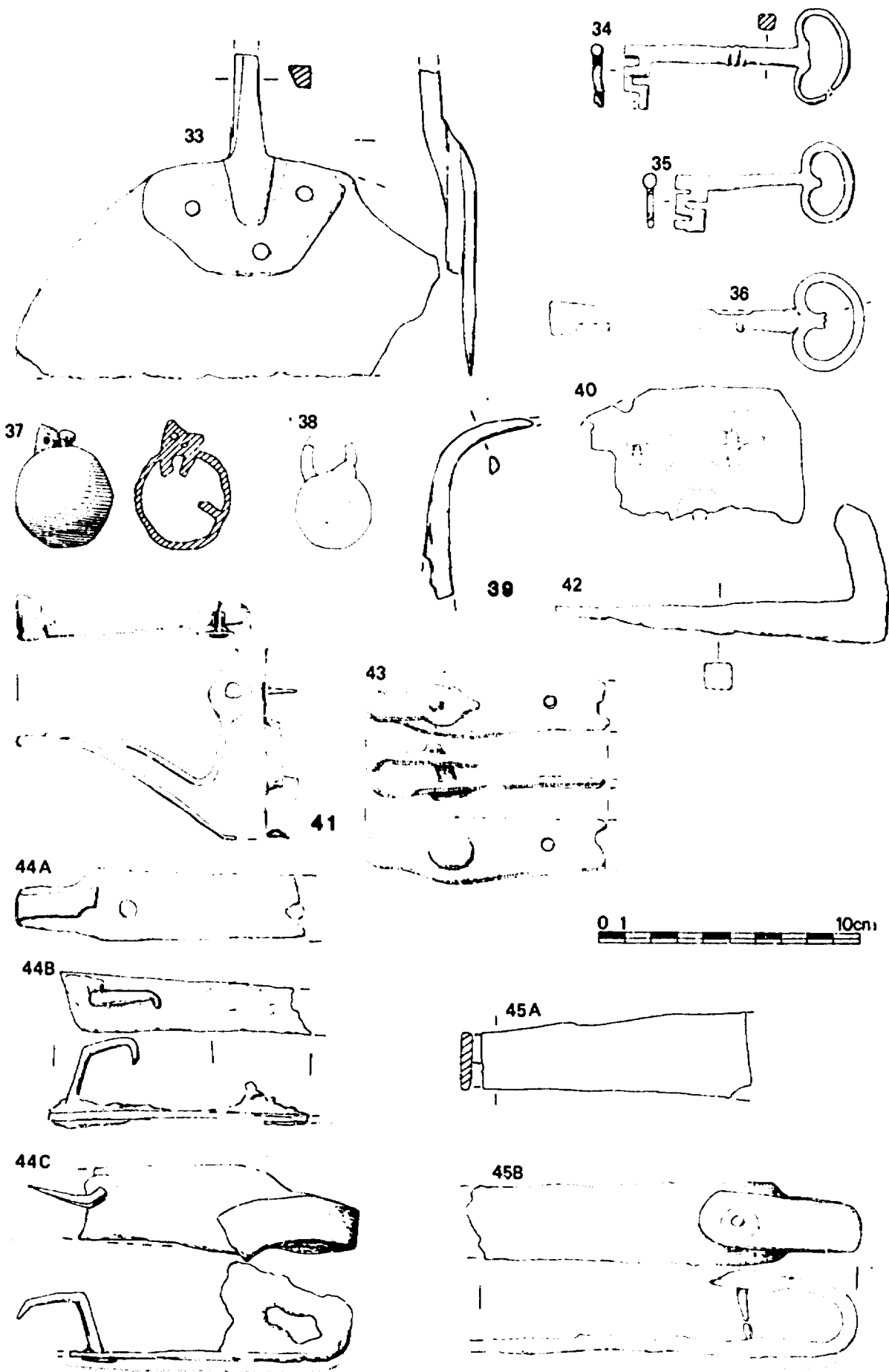

Fig.127 Iron Objects

IRON OBJECTS

33. Hoe, tang riveted to blade. A SF647, F56, L56 Early-mid 19th-cent. context.
- 34-36. Keys, No. 34 with moulded stem, No. 36 with stem damaged but hollow only for depth of bit, itself now lost.
34. A. SF508, F45, L171 Mid-late 17th-cent. context;
35. A SF223, L2 (2M, 108/1012) Unstratified;
36. A SF41, L2 (2M, 108/1010) Unstratified.
- 37-38. Globular padlocks similar to those from Chingley Forge Kent.¹ No.37 has lost its internal mechanism, as may ^{No.}38. Both have incomplete shackles.
37. A SF1293, F1023, L1135 Mid 17th-cent. context (+ some 17th-cent. material); 38. A SF627, F17, L2012 Mid-late 17th-cent. context.
39. Broken stapled hasp. A SF663, F82, L83 Early-mid 17th-cent. context.
40. Fixed lock with fragmentary back plate retaining collar, bolt, spring and retaining staples. A lock of different form but with a similar mechanism came from Oxford Castle.² A SF1278, F1003, L1010 (= F1023) 17th-cent context.
41. Spring from fixed lock. The spring held the tumbler in the bolt, as post-medieval locks from Stillingfleet, N. Yorks.³ and elsewhere⁴ show. A SF30, L2 (2M, 116/1010) Unstratified.
42. Hinge pivot, A SF122, L2 (2M 112/996) Unstratified.
- 43-45 Strap hinges, all with nailed U-shaped eyes.
43. A SF98, F98, L90 16th-cent. context;
44. A SF1117, L2 (2M 106/1002) Unstratified;
45. A SF103, L2 (2M 116/998) Unstratified.

1 Ian H. Goodall in David Crossley, The Bewl Valley Ironworks, Kent c. 1300-1730, (1975) 73; Fig. 35, Nos.102-3.

2 Ian H. Goodall, 'Iron Objects' in T.G. Hassall, 'Excavations at Oxford Castle, 1965-73', Oxoniensia, xli (1976), 300; Fig.28, No.59.

3 P.V. Addyman and Ian H. Goodall, 'The Norman Church and Door at Stillingfleet, North Yorkshire', Archaeologia, cvi (1979), 97; Pl.XXXIa.

4 I. Noël Hume, A Guide to Artefacts of Colonial America (1970, New York), 243-48; Fig.77a.

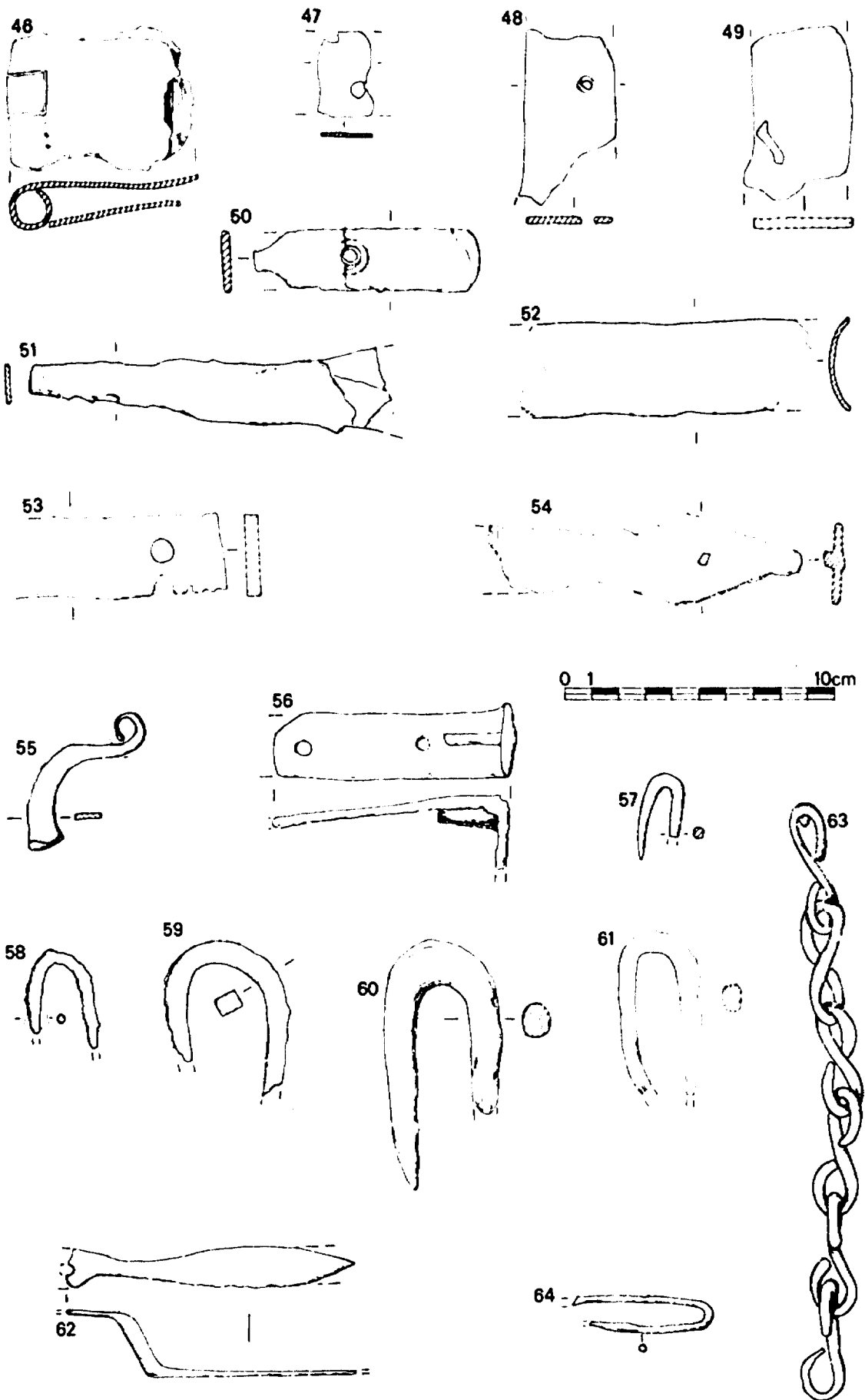

Fig.128 Iron Objects

IRON OBJECTS

46. Pinned hinge. A SF123, L2 (2M, 118/1016) Unstratified.
- 47-53 Strap fragments.
47. A SF2207, F2531 16th-cent. context;
48. A SF2204, F2531 16th-cent. context;
49. A SF670, F129, L103 (=F149) Mid-late 17th-cent. context;
50. A SF656, F60, L34 Mid 18th-cent. context;
51. A SF655, F60, L34 Mid 18th-cent. context;
52. A SF1308, F2005, L2021 Early 19th-cent. context;
53. A SF651, F56, L56 Early-mid 19th-cent. context.
54. Strap hinge terminal. A SF119, L2 (0.5M, 117.5/1012) Unstratified.
55. Scroll from hinge terminal. A SF1085, L2 (2M, 108/994) Unstratified.
56. Angle Strap. A SF652, F57, L57 Mid-late 18th-cent. context.
- 57-61 U-shaped staples.
57. A SF1244, F1529, L1 Early 17th-cent. context;
- 58 and 59. A SF646, F55, L55 Late 17th-cent. context;
60. A SF107, F44, L47 Late 17th-cent. context;
61. A SF121, L2 (2M, 116/998) Unstratified.
62. Broken window bar with canted, nailed terminal. A SF665, F1, L102 Mid-late 17th-cent. context.
63. Chain. A SF654, F60, L34 Mid 18th-cent. context.
64. Chain link. A SF1033, F60, L34 Mid 18th-cent. context.

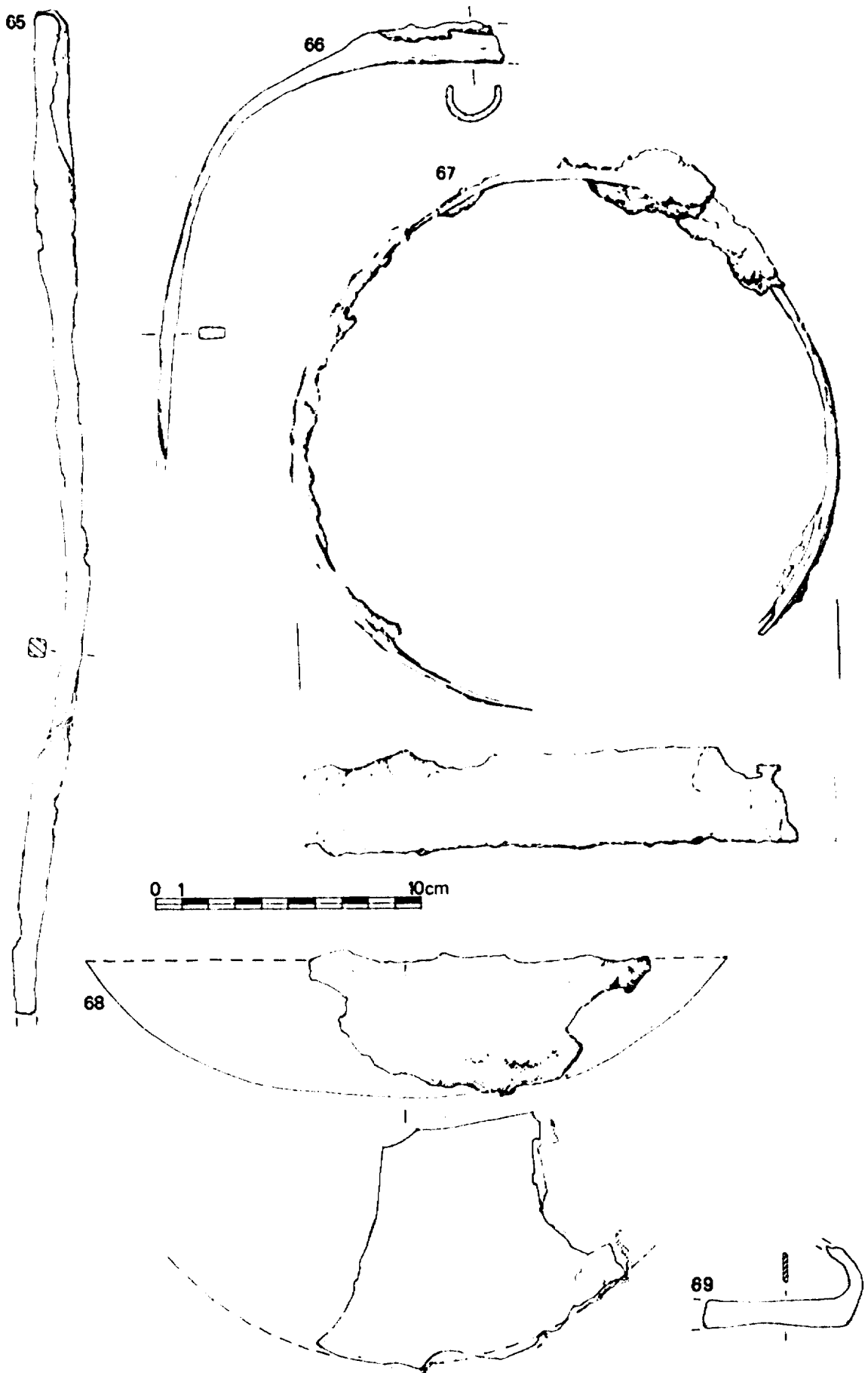

Fig.129 Iron Objects

IRON OBJECTS

65. Poker? A SF643, F45, L188 Mid-late 17th-cent. context.
66. Bucket handle with shaped handle hold. A SF648, F56, L56 Early-mid 19th cent. context.
67. Bucket hoop. A SF224, L2 (2M, 116/1010) Unstratified.
68. Vessel fragment, ?cast iron. A SF222, L2 (2M, 100/1010) Unstratified.
69. Strike-a-light. A SF635, F17, L15 Mid-late 17th-cent. context.

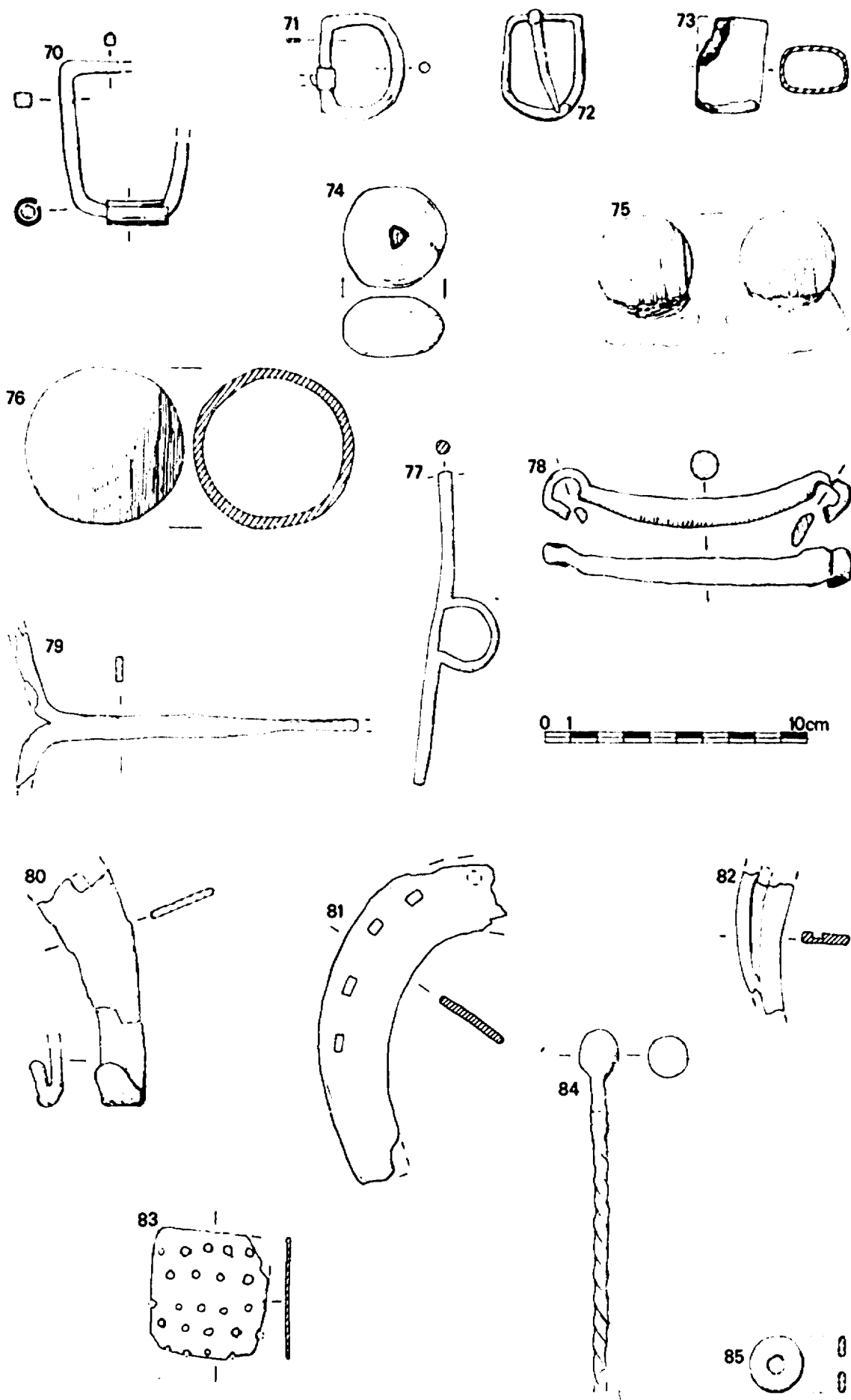

Fig.130 Iron Objects

IRON OBJECTS

- 70-72. Buckles.
70. A SF660, F78, L97 16th-cent. context; 71. A SF639, F41, L91 16th-cent. context; 72. A SF2078, L63 Undated context.
73. Chape. A SF626, F17, L2012 Mid-late 17th-cent. context.
74. Sword Pommel. A SF630, F17, L2010 Mid-late 17th-cent. context.
75. Iron shot? 36mm diameter, 180gm weight.
A SF642, F45, L171 Mid-late 17th-cent. context.
76. Hollow sphere. A SF2256, F2504, 18 (= F2011) Early 17th-cent. context.
77. Cheekpiece from bridle bit. A SF588, F129, L103 (= F149) Mid-late 17th-cent. context.
78. Mouthpiece link from bridle bit. A SF587, F129, L103 (= F149) Mid-late 17th-cent. context.
79. Currycomb handle. A SF1307, F2003, L2015 (=F17) Mid-late 17th-cent. context.
- 80-82 Horseshoe fragments, No. 82 with a fullered groove and so intrusive in its medieval context.
80. A SF640, F41, L91 16th-cent. context; 81. A SF1295, F1023, L1135 Mid 17th-cent. context (+ some 17th-cent. material);
82. A SF1236, F1522, 11th-cent. context.
83. Sheet with rows of holes. A SF653, F57, L57. Mid-late 18th-cent. context.
84. Twisted rod with knobbed terminal. A SF649, F56, L56 Early-mid 19th-cent. context.
85. Washer. A SF36, L2 (2M, 118/994) Unstratified.

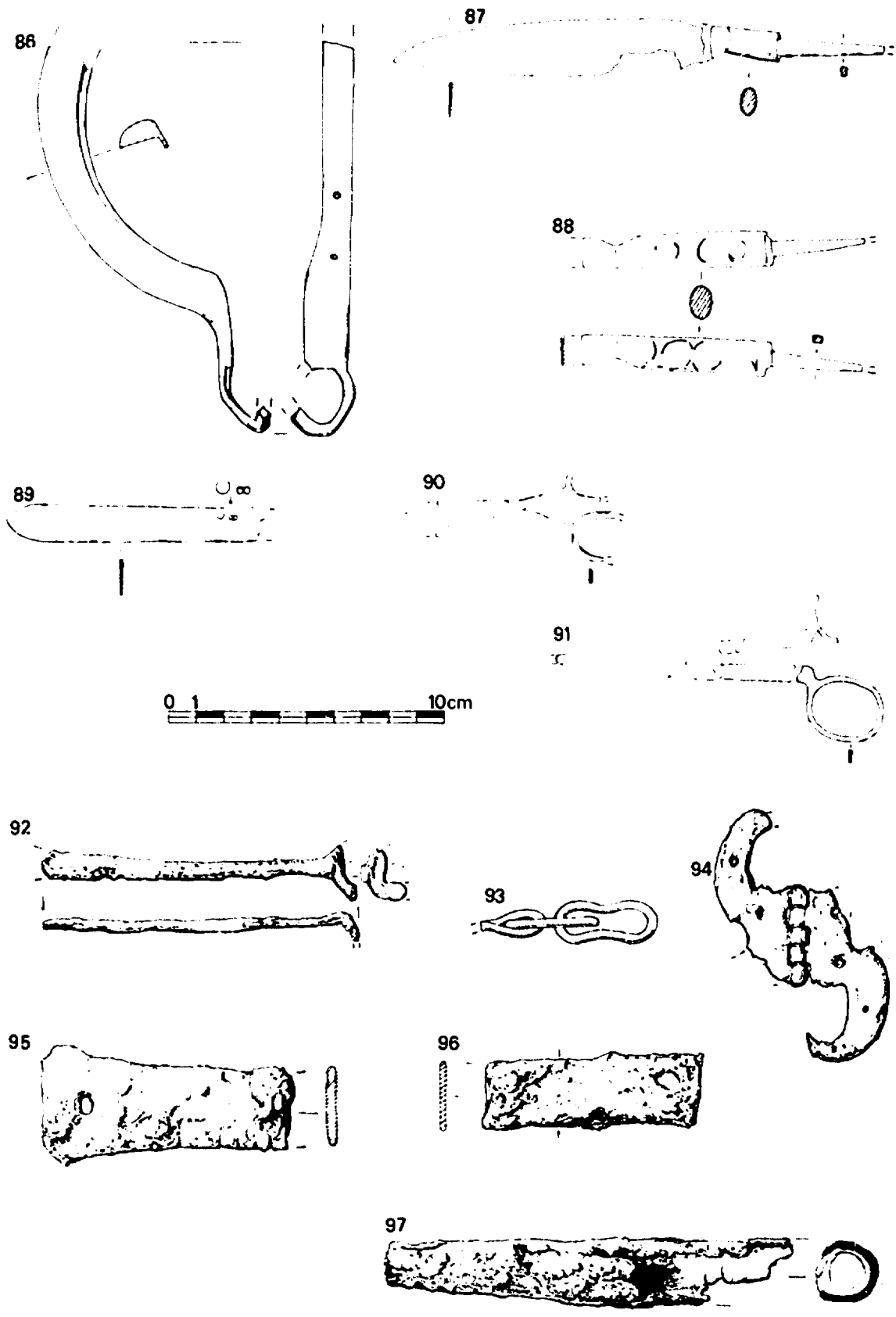

Fig.131 Iron Objects

IRON OBJECTS

86. Object. A SF2079, L2 (2M, 100/1008) Unstratified.

Site B, Greyfriars

87. Knife with whittle tang, circular section bolster and complete blade. B XIV SF1, F2 Early-mid 17th-cent. context .
88. Knife with whittle tang, circular section bolster and stub of blade. The bolster is inlaid along both sides with silver wire in simple geometric patterns. Such inlay is found on other 17th-century knives,¹ as well as on swords, spurs etc.² B IV SF85, F13 Mid-late 17th-cent. context.
89. Knife blade with cutler's mark, not inlaid. B IV SF65, F13/1 Mid-late 17th-cent. context.
90. Scissors with centrally-set finger loops. B IV SF75, F49 Mid-late 17th-cent. context.
91. Scissors with offset finger loops. B V SF17-18, F2/1 Early-mid 18th-cent. context.
92. Padlock key , bit and stem incomplete. B III SF7, F4, L2 Early-mid 17th-cent. context.
93. Incomplete chain link. B X SF30, F22 Mid 18th-cent. context.
94. Broken pinned hinge of simplified cockshead shape, comparable with examples from Bolingbroke Castle, Lincs.³ B IV SF60, F13/1 Mid-late 17th-cent. context.
- 95- Strap hinge fragments, No.95 with a simply-shaped terminal.
96.
95. B XIV SF9, F2 Early-mid 17th-cent. context; 96. B X SF24, F26 Mid 18th-cent. context (+ intrusive 19th-cent. material).
97. Broken tapering tube. B IV SF84, F13 Mid-late 17th-cent. context.

1. Compare with a knife from Hull: Ian H. Goodall, 'Iron Objects', in Peter Armstrong, Excavation in Sewer Lane, Hull, 1974, (Hull Old Town Report Ser. No. 1, East Riding Archaeologist, iii) (1977), 65; Fig. 27, No. 89.

2. Blanche Ellis, 'Spurs', in E. Russell et al, 'Excavations on the site of the deserted medieval village of Kettleby Thorpe, Lincolnshire', Journal of the Scunthorpe Museum Society, Ser. 3, No. 2, (1974), 40; Fig. 19, No. 40; Pl. 1b.

3. Ian H. Goodall, 'Iron Objects', in Peter Drewett, 'The Excavation of the Great Hall at Bolingbroke Castle, Lincolnshire, 1973', Post-Medieval Archaeology, x (1976), 26; Fig. 14; Nos. 28-29.

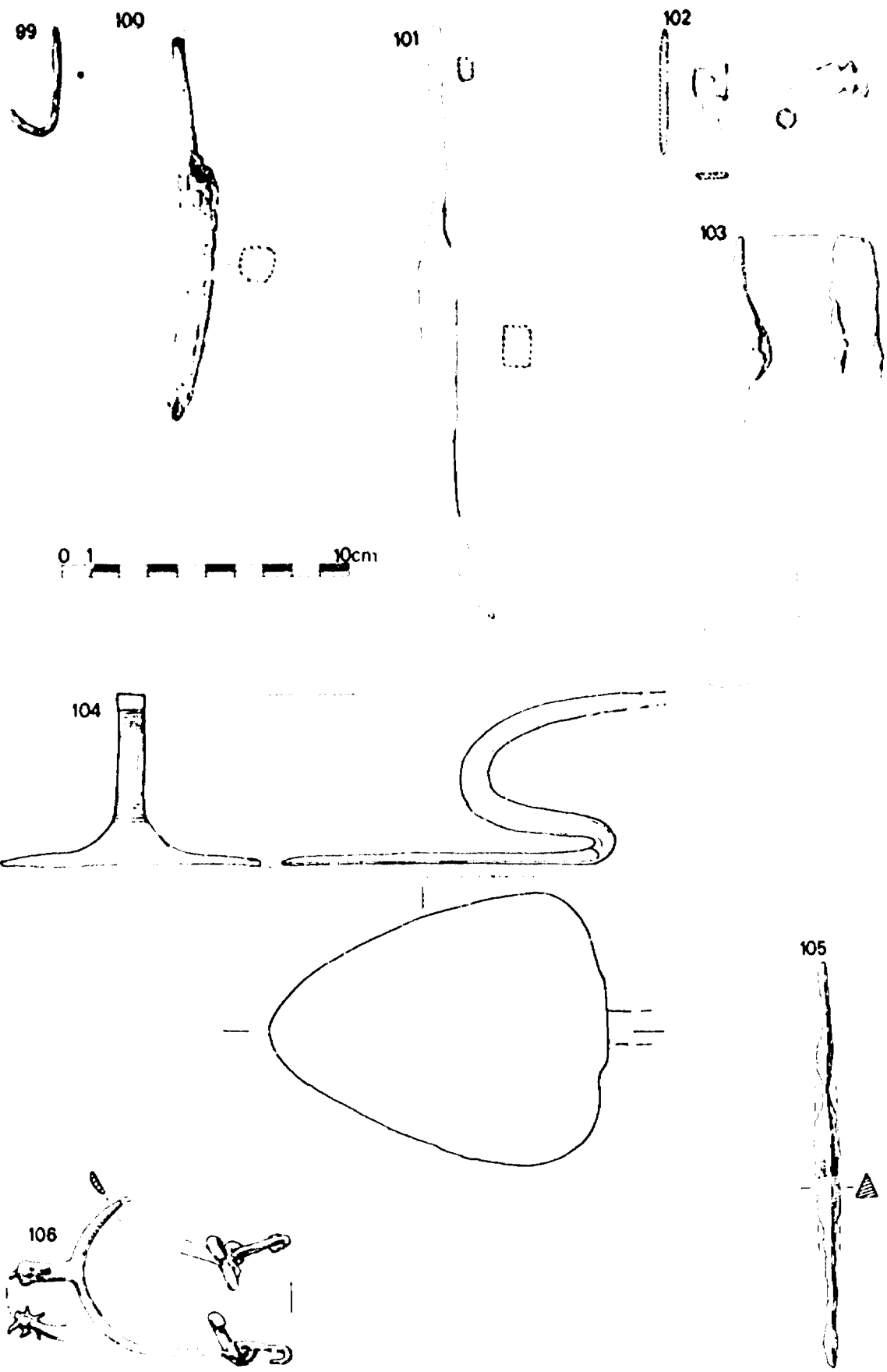

Fig.132 Iron Objects

IRON OBJECTS

98. Two short lengths of 2mm diameter wire twisted together, total length 54mm (not illustrated). B V SF20, F2/1 Early-mid 18th-cent. context.
99. Broken fishhook. B X SF31, F26 Mid 18th-cent. context (+ intrusive 19th-cent. material).
- 100- Rake and harrow tines with broken stems. The stems were set in a wooden frame and clenched over the top. Rake prongs are known from a number of British and Colonial contexts.¹
100. B IX SF5, F2 Early 17th-cent. context; 101. B IX SF4, F2 Early 17th-cent. context.
102. Small hammer, the solid stem with a moulded base and the head with an inlaid rectangular pattern. Tool perhaps used by a craftsman in non-ferrous metal. B V SF19, F2/1 Early-mid 18th-cent. context.
103. Lugged side arm and part of blade of spade-iron. B X SF75, F34 Early-mid 18th-cent. context.
104. Mason's trowel, tang distorted. B VII SF3, F4 Early 18th-cent. context (+ some intrusive mid-late 18th-cent. material).
105. Tanged triangular or three-square file used to file acute internal angles. B VI SF47, F4 Early 19th-cent. material.
106. Blanche Ellis writes:- Small iron rowel spur for the right foot. Straight D-section tapered sides, only a broken stump remaining of one, the other with evenly set figure-8 terminal retaining two thin attachments for the leathers with flattened hooks. Short, slightly curved oval neck projects from the lower half of the surface encircling the heel, it swells at the rowel bosses. Small rowel originally of 26 sharp points, now rusted into rowel box and damaged. The entire spur is very severely rusted; it may possibly have had silver decoration. English late 17th century. Overall length 85mm. Length of neck 22mm. Diameter of rowel about 16mm. Length of hook attachment 24mm. B IV SF29, F49 Mid-late 17th-cent. context.

¹ Ian H. Goodall, 'Iron Objects' in E. Russell et al. 'Excavations on the site of the deserted medieval village of Kettleby Thorpe, Lincolnshire', Journal of the Scunthorpe Museum Society, Ser. 3, No. 2, (1974), 34; Fig. 35.

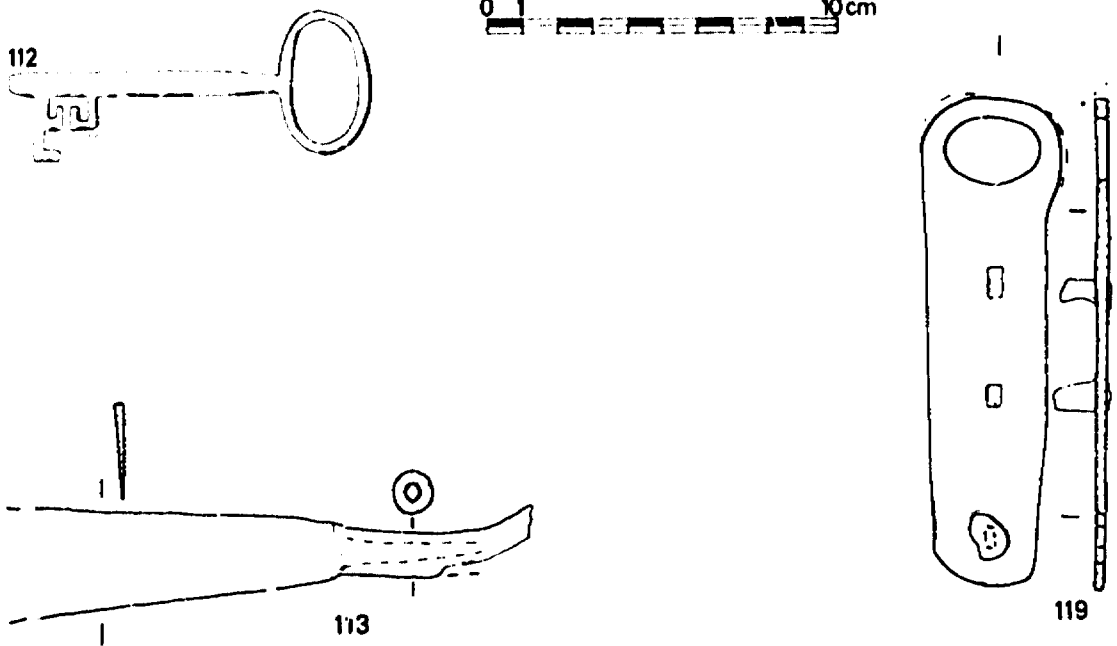
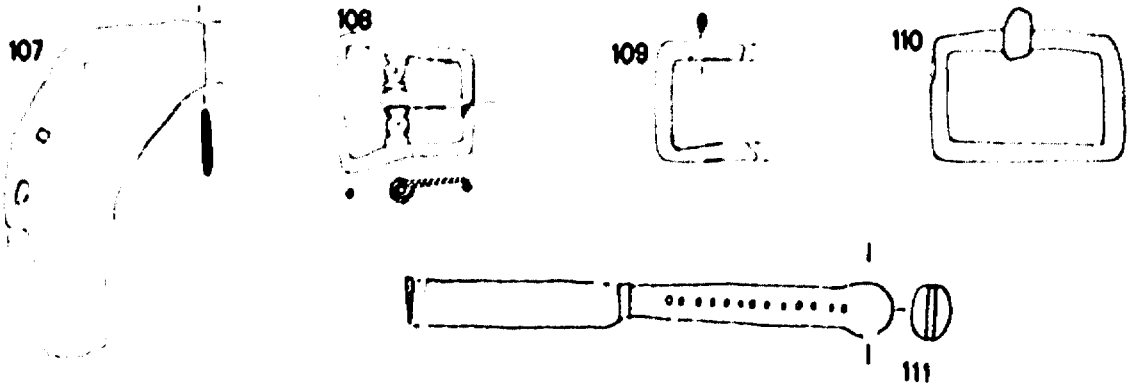

Fig.133 Iron Objects

IRON OBJECTS

107. Horseshoe arm with nailholes close to the outer edge. B XIV SF8, F2 Early-mid 17th-cent. context.
108. Buckle with shaped frame and plain pin swivelling on a moulded bar. Non-ferrous plating. B IV SF41, L17 Early 17th-cent. context.
109. Rectangular buckle frame, now broken. B X SF28, F22 Mid 18th-cent. context.
110. Rectangular buckle loop with pin. B X SF76, F26 Mid 18th-cent. context (+ intrusive 19th-cent. material).
111. Scale tang knife with broken blade, shoulder plates (?) and bone handle with iron rivets alternating with pairs of copper alloy pins. B IX SF2, F3 Early-mid 17th cent. context.
- 111a. Diamond-shaped rove, 30mm side, not illustrated. B IV SF79, F40 L2 Late 17th-cent. context.
Timber nails with head of four types were found: flat square head, domed, rectangular with faceted top, rectangular.

Site W, Westgate

Only Nos. 112, 113 and 119 are illustrated.

112. Key. W SF10, F7 Mid 18th-cent. context.
113. Whittle tang knife, large broken blade, remains of wooden handle. W F22 Early-mid 18th-cent. context.
114. Rod, length 283mm, diameter 4mm. W SF75, F22 Early-mid 18th-cent. context.
115. Wire, length 78mm, diameter 3mm. W SF77, F22 Early-mid 18th-cent. context.
116. T-shaped nail. W SF81, F22 Early-mid 18th-cent. context..
117. Bar, length 94mm. W SF76, F22 Early-mid 18th-cent. context.
118. Bar, length 89mm. W SF68. F118 Mid 19th-cent. context.
119. Handle support from wooden bucket with loop for handle and two of three nails surviving. W F117 16th-cent. context.

IV E5 - E14 Blank

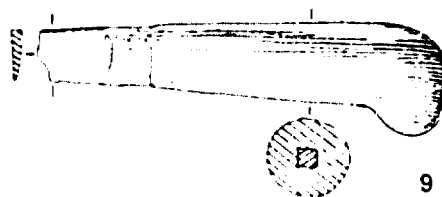
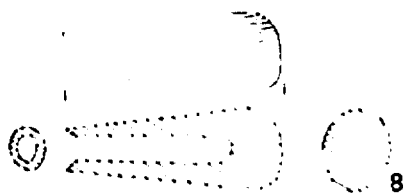
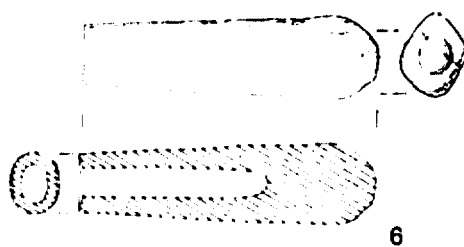
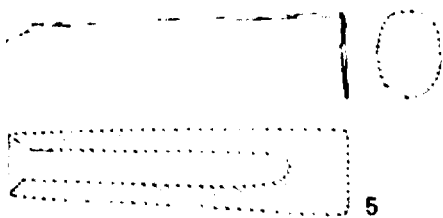
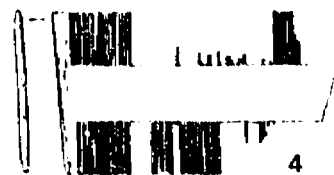
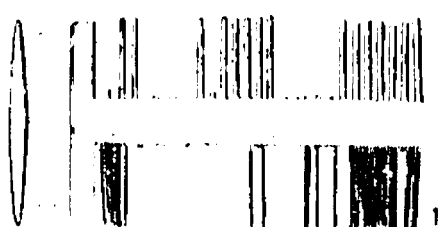

Fig.134 Bone and Ivory Objects

BONE AND IVORY OBJECTS BY GEOFF EGAN AND MARTIN HENIG, IDENTIFICATION OF
BONE AND IVORY BY PHILIP ARMITAGE AND BOB WILSON.

Figs. 134-39

Site A: 1-29; Site B: 30-44; Site D: 45; Site W: 46-53.

Site A, 31-34 Church Street by Geoff Egan and Martin Henig.
Identification of bone and ivory by Philip Armitage.

- 1-4. Ivory double-sided combs with fine and coarse teeth on opposite sides, except No.4.
1. A SF2016, F17, L2012 Mid-late 17th-cent. context.
 2. Fragment from comb thinner than No.1 (not illustrated).
A SF3302, F17, L15 Mid-late 17th-cent. context.
 3. With incised guidelines for tooth cutting on all four edges, probably 18th century. A SF17, L2 (2M, 110/1006)
Unstratified.
 4. Fine teeth on both sides. A SF2153, F13, L.1 Late 18th-cent. context.
- 5-10. Knife or fork handles, all of elephant ivory, except No.10, and lathe-cut centrally to accept a tang
5. Oval Section. A SF179, F57, L57 Mid-late 18th-cent. context.
 6. Rounded diamond section. A SF507, F45, L171 Mid-late 17th-cent. context.
 7. As No.6 but flat end and slight nib on underside. Not illustrated. A SF10 L2 (2M, 108/1012) Unstratified.
 8. Small, oval section (possibly tool handle).
A SF2019, F2003, L2015 (=F17) Mid-late 17th-cent. context.
 9. Knife handle of pistol grip form, remains of blade with bolster; see also Iron Objects No.15, A SF1001, L2 (2M, 108/1012) Unstratified.
 10. As No.9 but made of antler. Not illustrated.
A SF3326, F60, L34 Mid 18th-cent. context.
 11. Number not used.
 12. Small bone handle, rectangular section, pierced for tang.
A SF551, L2 (2M, 106/1008) Unstratified.

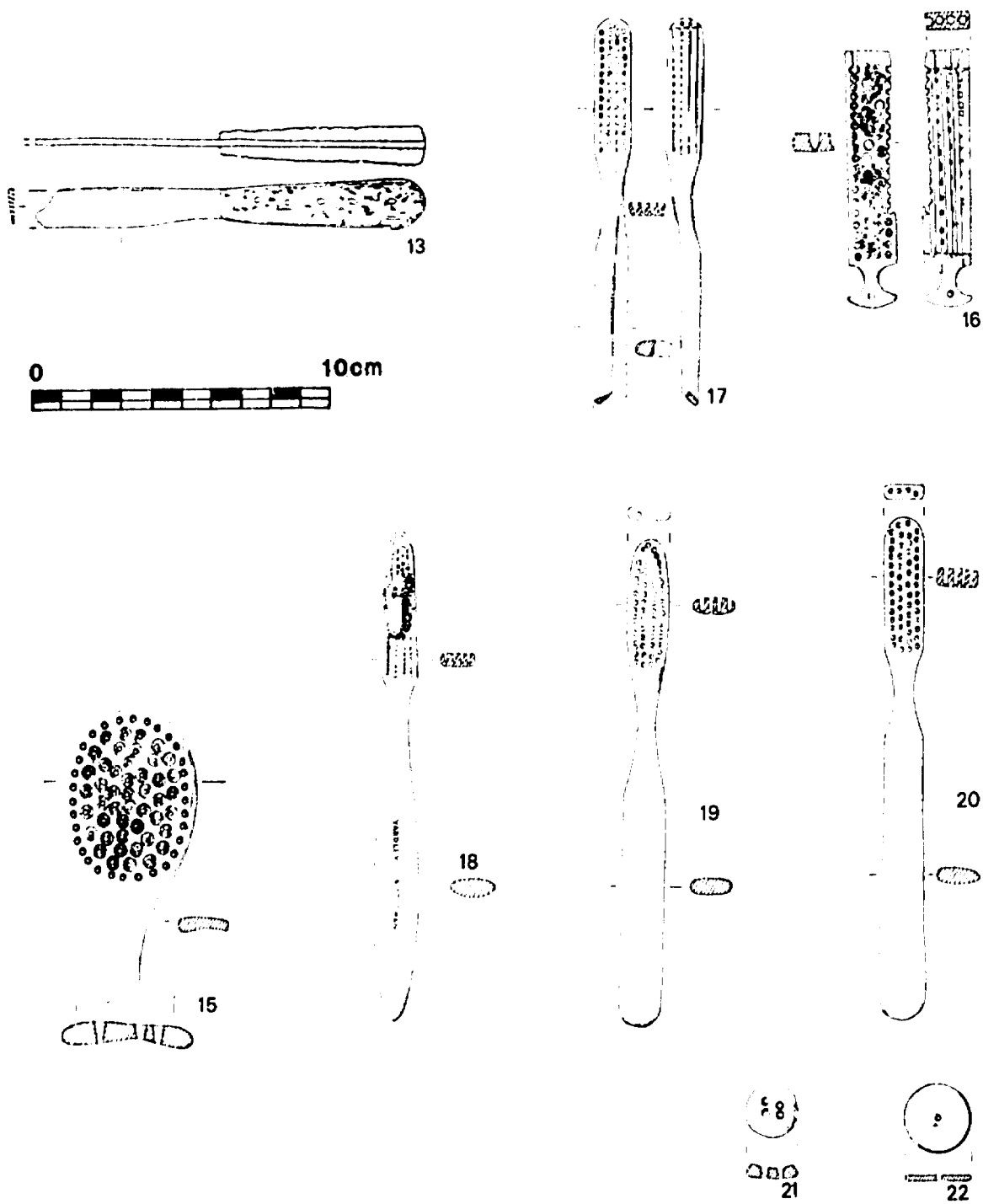

Fig.135 Bone Objects

BONE AND IVORY OBJECTS

13. Handle of scale tang knife with both scales of red or roe deer antler held by five iron rivets; see also Iron Objects No.8; A SF79, F71, L44 Early 17th-cent. context.
14. Fragment of antler handle scale with rebate for nib or bolster and hole for rivet. Not illustrated. A SF3303, F1003, L1027=(F1023) 17th-cent. context.
15. Probably a hairbrush, though rather small, bone, perhaps from cattle metacarpus. A SF183A, F72, L82 Mid 19th-cent. context.
16. Nailbrush with ornate shape and single row of end bristles. Some bristles survive, bone stained green in slots on back. A SF2150, F13, L11 Late 18th-cent. context.
17. Toothbrush, '8VS' stamped below the bristles, some of which survive,? 'J.O/G. NIGHTINGALE AND SON' stamped on the handle; bone, stained, green in slots on back. A SF175, F56, L56 Early-mid 19th-cent. context.
- 18-20. Three bone toothbrushes: No.18 with some bristles preserved by iron corrosion products and 'YARDLEY/& STATHAM' stamped on the handle; No.19 with tiny bone pegs entering four of the bristle holes from the side. A SF184A-C, F66, L74 Mid 19th-cent. context.
21. Button: turned concavo-convex disc with four holes slightly offset from centre, bone. Cf. Noël Hume's button Type No.20.¹ A SF183C, F72, L82 Mid 19th-cent. context.
22. Button: turned disc with a central hole, possibly from a composite button, bone. Cf. Noël Hume's button Types Nos.4 and 15.² A SF183B, F72, L82 Mid 19th-cent. context.

1. I. Noël Hume, A Guide to the Artefacts of Colonial America (1974, New York), 91.

2. Ibid.

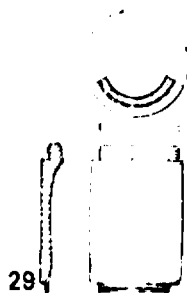
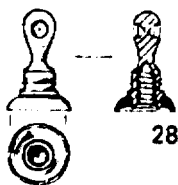

Fig.136 Bone and Ivory Objects

BONE AND IVORY OBJECTS

23-25. Off-cuts.

23. Strip from cattle or horse, rib from which discs have been cut with median ridges on the edges of the circles, indicating cutting from both sides. (Cf. No.22 above). A SF504, F45, L171 Mid-late 17th-cent. context.
24. Off-cut, possibly from comb-making, for which the piece is a suitable length (108mm); cut tangentially, at right angles and at each end, elephant ivory. A SF2148, F17, L2012 Mid-late 17th-cent. context.
25. As No.24 but shorter (70mm). Not illustrated.
A SF3301, F17, L2012 Mid-late 17th-cent. context.
26. Awl? Horse metapodial with shaft sharpened to a point. Length 100mm. Not illustrated. A SF3304, F1528, L1 16th-cent. context.
27. Two thin scales of bone tapering in width, one end neatly finished (not pierced), lengths 82 and 70 mm. Use unknown. Not illustrated. A SF3305, F60, L34 Mid 18th-cent. context.
28. Turned object in two parts: knob with opposed drilled holes (for a ring drop handle?), screwing into base? with a concave bottom and screw-threaded central hole. Bone. A SF550, L2 (2M, 112/1004) Unstratified.
29. Part of a cylindrical tube with screw threads internally at a slight angle and externally at both ends. Bone. A SF227, L2 (2M, 114/1012) Unstratified.

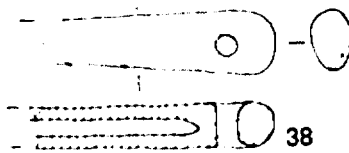
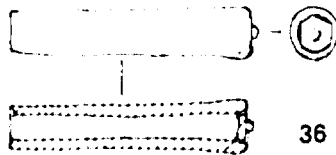
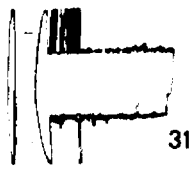

Fig.137 Bone and Ivory Objects

BONE AND IVORY OBJECTS

Site B, Greyfriars by Martin Henig.

30-34. Ivory double-sided combs with fine and coarse teeth on opposite sides except Nos. 31 and 34.

30. Fragment 51mm wide, surviving length 44mm. Not illustrated. B III SF3, F4, L2 Early-mid 17th-cent. context.

31. Comb fragment with convex endplate and teeth of same fine module on both sides. Width 42mm, surviving length 38mm. B IV SF7/1, L1 Unstratified (Early 19th-cent. material).

32. Fragment, teeth broken. Not illustrated. B IV SF7/2, L1 Unstratified (Early 19th-cent. material).

33. Comb fragment with rectangular endplate. Width 48mm, surviving length 31mm. Not illustrated. B IV SF48 L23 ?Medieval context.

34. Fragments from two convex-ended combs. Teeth fine (14 to 10mm): width 44.5mm; very fine (18-10mm) and shorter: width 44mm. Not illustrated. B VII SF4, F5 Mid 19th-cent. context.

35-41. Cutlery handles, pierced for tang.

35. Ivory, round tapering with rounded end. Length 77mm. Not illustrated. B III SF5, F4, L2 Early-mid 17th-cent. context.

36. Hollow bone handle with end plugged by a circular plate with knob, also of bone. Cf. knife from Basing House.¹ B IV SF64, F4, L1 Undated context.

37. Antler: naturally curved, iron end cap. Length 83mm. Not illustrated. B IV SF68, F44 Early-mid 18th-cent. context.

38. Ivory handle, diamond section, split along length, pierced through end for suspension. Length 69mm. B IV SF69, F44 Early-mid 18th-cent. context.

1. S. Moorhouse, 'Finds from Basing House, Hampshire (c. 1540-1645): Part Two', Post-Medieval Archaeology, v (1971), 35-76; 36f; Fig. 17, No. 9.

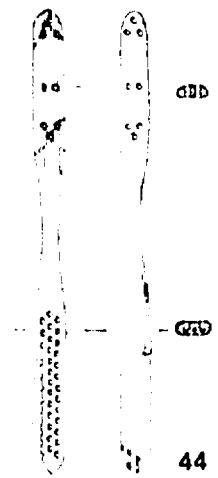
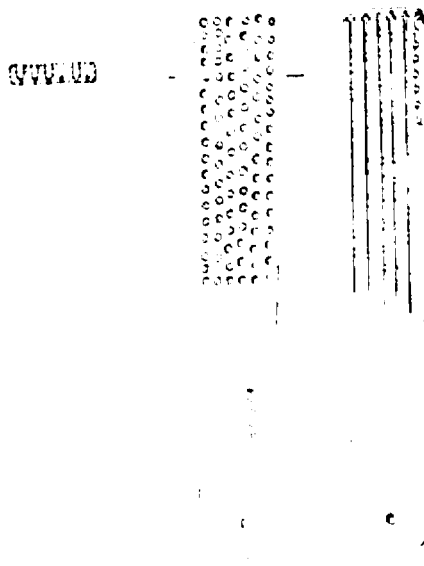
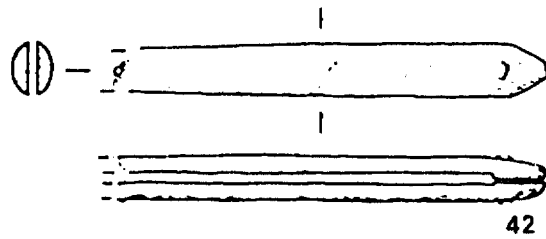

Fig. 138 Bone Objects

BONE AND IVORY OBJECTS

35-41. Cutlery handles, pierced for tang (con.).

39. Ivory, diamond section, incomplete. Length 67mm. Not illustrated.
B X SF73, F26 Mid 18th-cent. context (+ intrusive 19th-cent. material).
40. Ivory, round tapering, notched towards ?blade. Not illustrated.
B X SF74, F26 Mid 18th-cent. context (+ intrusive 19th-cent. material).
41. Bone, rectangular section, Length 84mm. Not illustrated.
B XIV SF3, L13 Medieval context.
42. Pair of handle plates (?antler) from clasp knife or razor with slot between for pivoting blade. Remains of iron rivets at both ends. B VII SF18, F4 Early 18th-cent. context (+ intrusive late 18th-cent. material).
43. Brush, bone, curved, with bristles missing. Traces of copper alloy wire for anchoring bristles visible in slots cut in back. Handle stamped with name 'PRATER' and pierced for suspension.
B X SF21, F36 Mid 19th-cent. context.
44. Toothbrush, holes for missing bristles at both ends on opposing sides and slots cut for anchorage. B V SF13, F11 Early-mid 19th-cent. context.
- 44a. Fragment of handle plate from scale tang knife, pierced for rivet. Cut and polished rib. Width 13mm. Not illustrated.
B V SF8, L7 Undated context.

Site D, Littlegate

45. Comb fragment, ivory, with coarse and fine teeth on opposite sides. Width (estimate) 60mm. Not illustrated. D I SF11, L3 Unstratified (late 18th-cent. material).

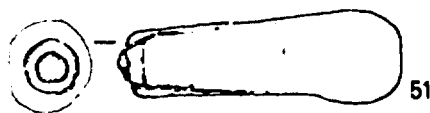
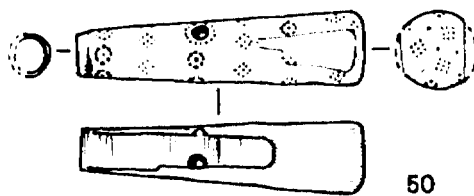
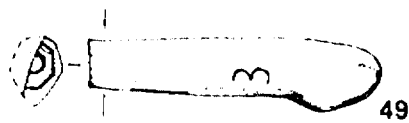
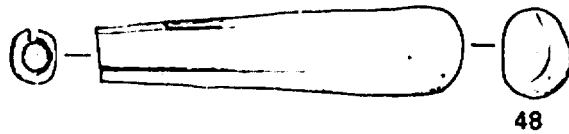
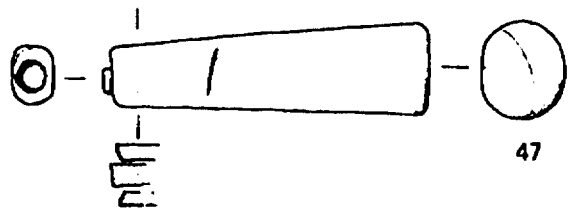

Fig.139 Bone and Ivory Objects

BONE AND IVORY OBJECTS

Site W, Westgate by Martin Henig

Bone Identification by Bob Wilson.

46. Double-sided ivory comb fragment; teeth of two different modules, i.e. coarse and fine, cut at constant length but edges curving out towards end. Width 41-49mm. Not illustrated. W SF2 F45 Mid-late 18th-cent. context.
- 47-52. Cutlery handles, all ivory except No.52.
47. Round section tapering, flat end. Notched and pitted on sides. W SF18, F22 Early-mid 18th-cent. context.
48. As No.47, but end rounded. W SF19, F22 Early-mid 18th-cent. context.
49. Fragment, probably octagonal in section and 'pistol grip' outline, highly polished. W F7 L2 Early 18th-cent. context.
50. Round section tapering, ornamented with rectangular and circular groups of depressions plugged with metal (?silver). One large hole possibly for rivet to hold tang in place. Double groove around neck. W SF97, F45 Mid-late 18th-cent. context.
51. Pistol grip, Cf. Nos.9 and 10. W SF95, F45 Mid-late 18th-cent. context.
52. Antler handle, naturally curved, with fragmentary iron end cap and bevelled to receive iron shoulder plate. Not illustrated. Length 87mm. W SF96, F45 Mid-late 18th-cent. context.
53. Convex bone cylinder, with screw thread running around interior. Stamped 'WARRANTED/(B)ADGER(H)AIR'-probably a shaving brush handle. Not illustrated. Length 26.5mm. Diameter 28mm. W SF99 Unstratified.

IV F13 - F14 Blank

WOODEN OBJECTS BY GWYNNE OAKLEY
SPECIES IDENTIFICATION BY MARK ROBINSON

The wooden objects were incompletely preserved and the original outlines are now uncertain, so they are not illustrated.

Site B, Greyfriars

1. Handle? of ring porous hardwood, possibly ash, preserved by iron tang within it, with possible iron end cap. Length 70mm. B IV SF67, F13, L1 Mid-late 17th-cent. context.

Site W, Westgate

2. Cleaved board, probably oak. Must have been waterlogged but now dried out. Minimum dimensions: Length 320mm, width 85mm, thickness 4-8mm. found with iron bucket handle support (Iron Object No.119) but not apparently attached to it. Could be a bucket stave or perhaps a shingle. W F117 16th-cent. context.

IV G2 - G3 Blank

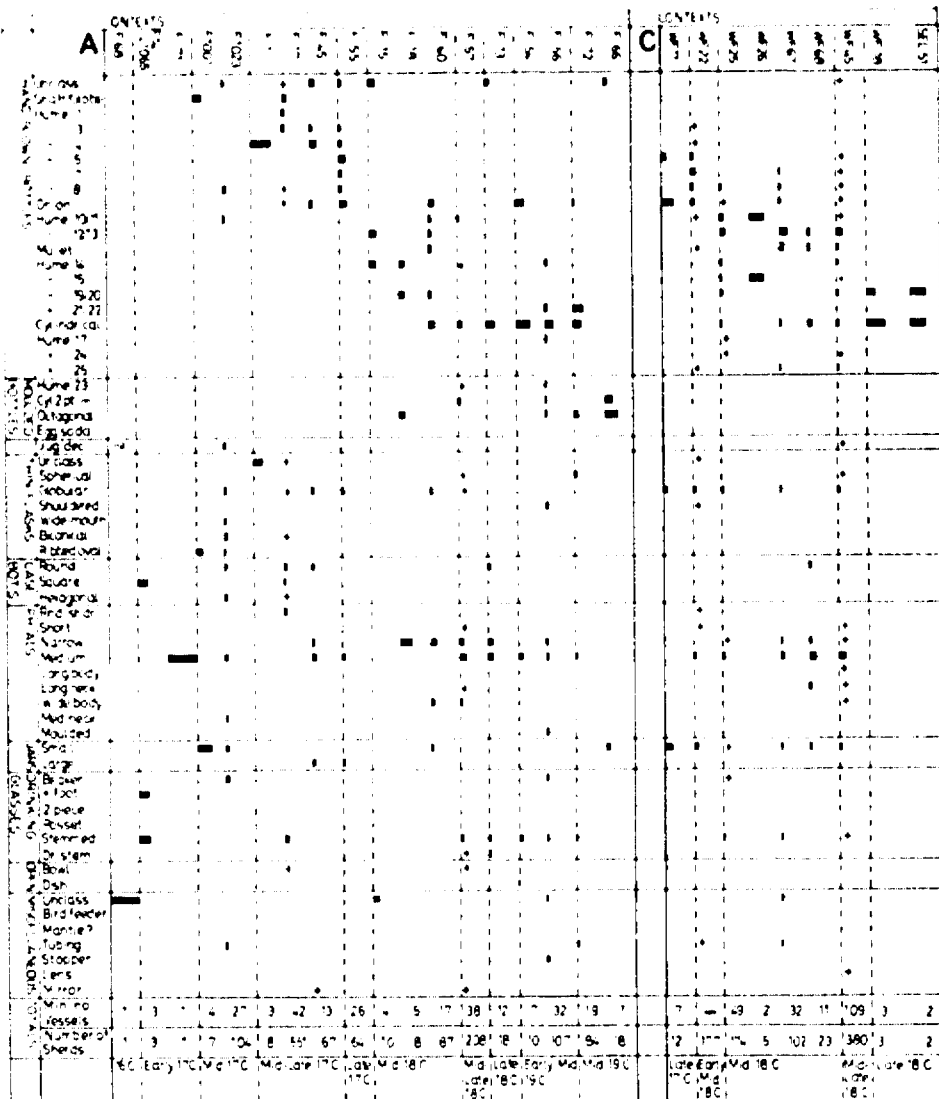

Fig.140 A histogram showing the percentage of glass vessel types from each context:
 A, Site A, Church Street
 C, Site SEL, Selfridges and Site W, Westgate,
 (features north of Church Street)
 + Indicates 2% or less

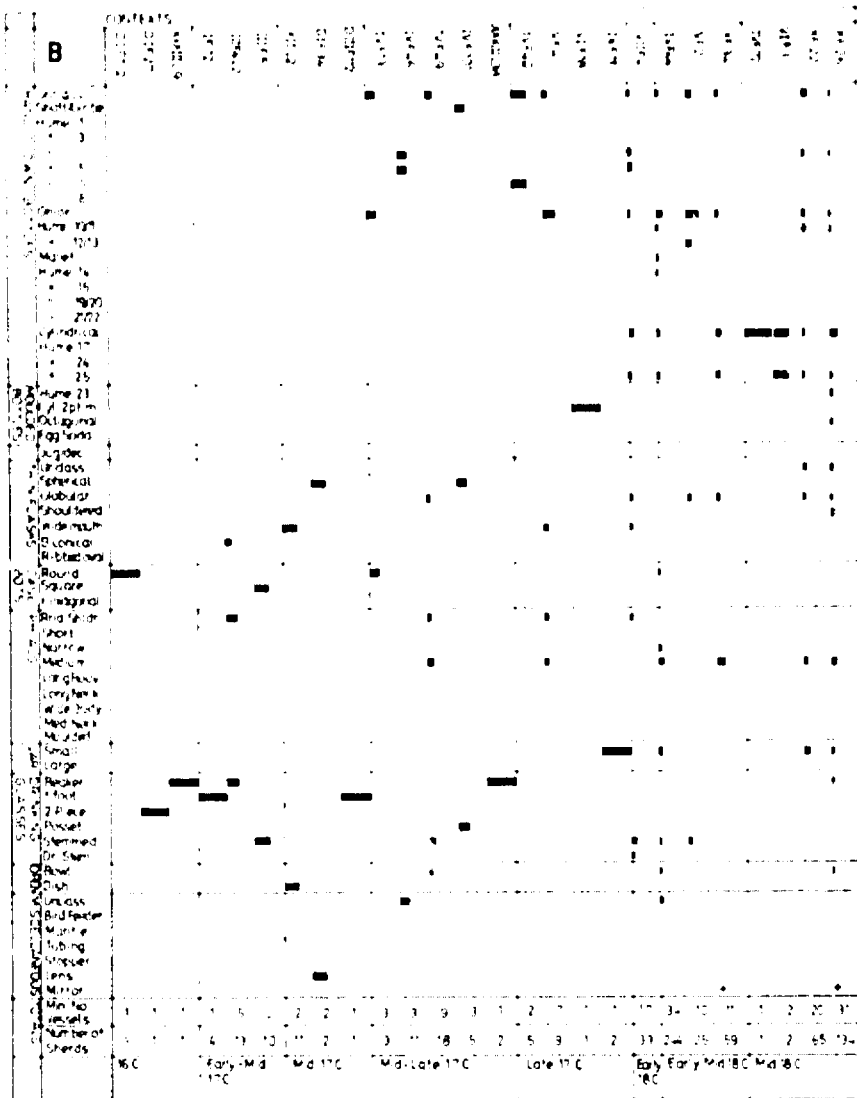

Fig.141 (Fig.140 continued)

A histogram showing the percentage of glass vessel types from each context:

B, Site B, Greyfriars and Site D, Littlegate

+ Indicates 2% or less

(Continued Fig. 142)

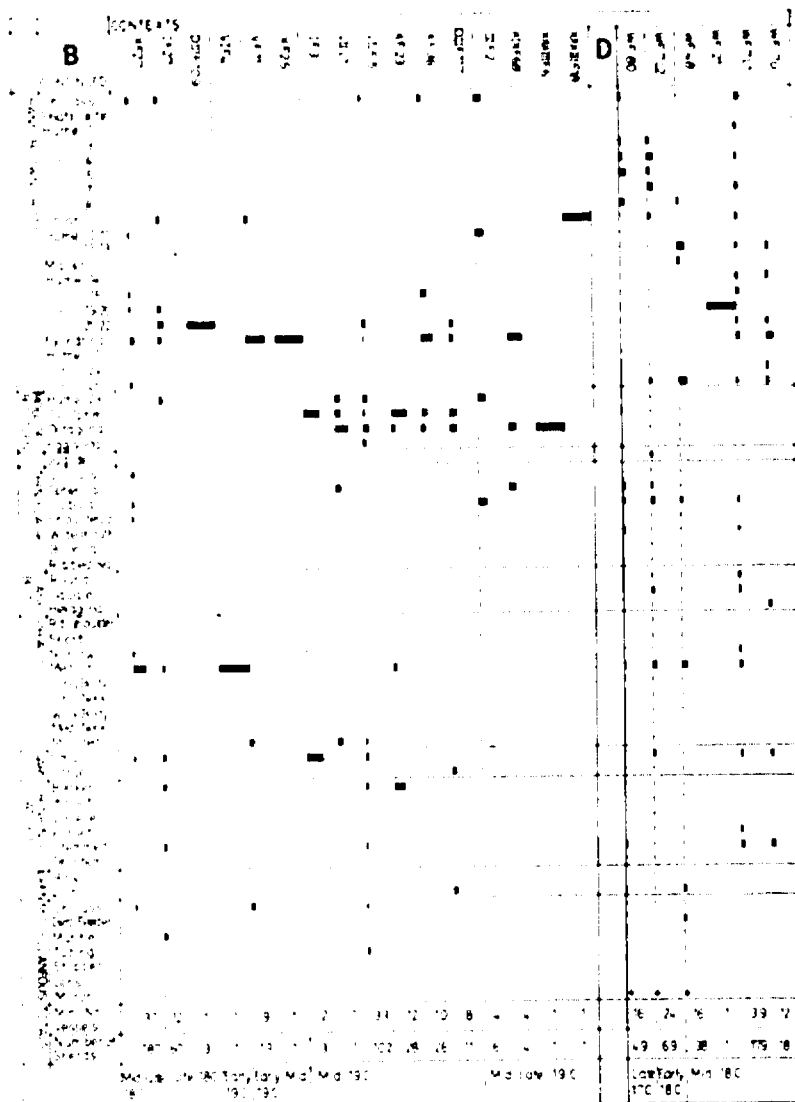

Fig.142 (Fig.141 continued)

A histogram showing the percentage of glass vessel types from each context:

B, Site B, Greyfriars and Site D, Littlegate
 D, Site W, Westgate (features south of Church Street)

+ Indicates 2% or less

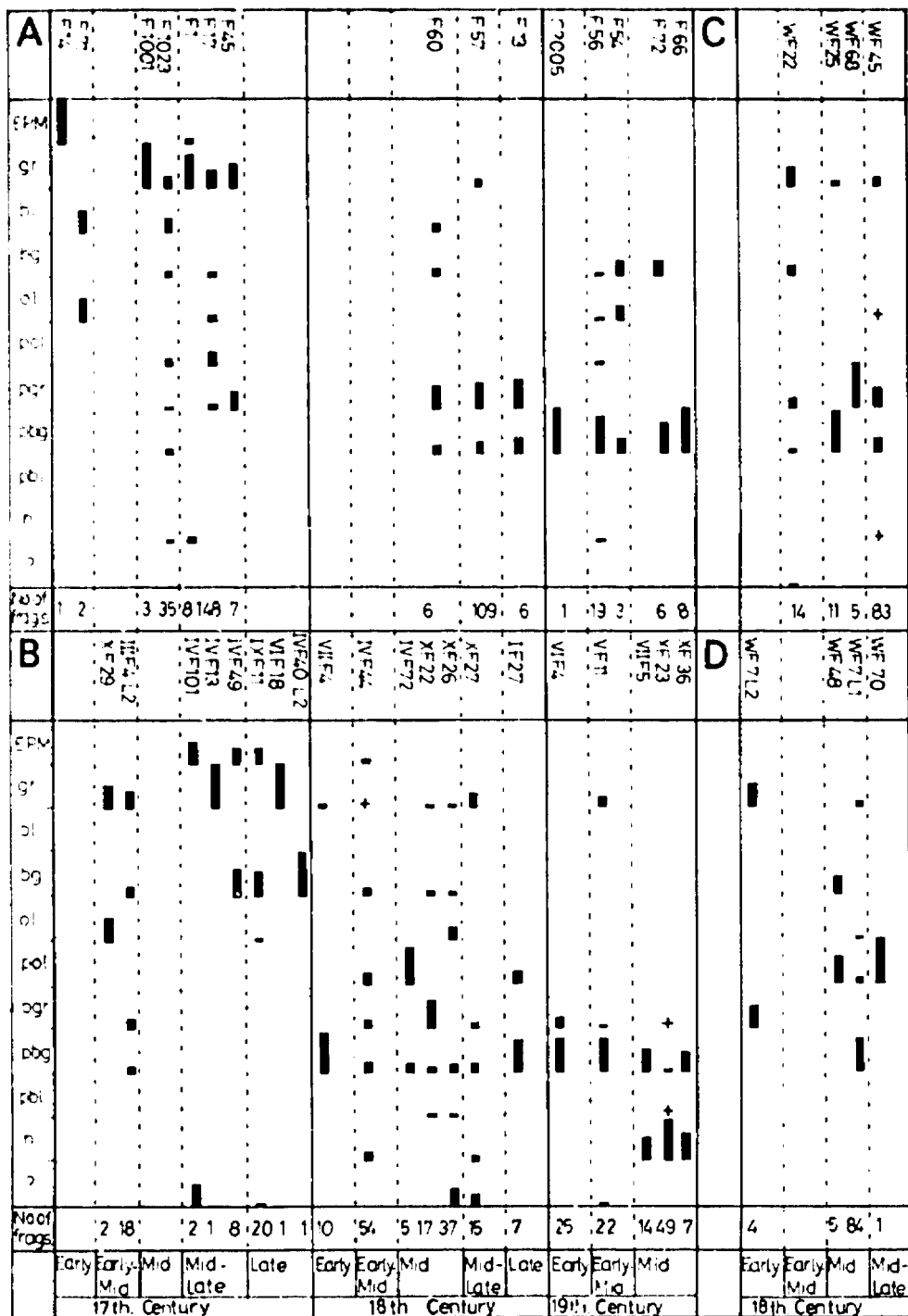

Fig.143 A histogram showing the percentage of window glass of early post-medieval type (EPM) and of different colours from each context:

- A, Site A, Church Street
- B, Site B, Greyfriars
- C, Site W, Westgate (features north of Church Street)
- D, Site W, Westgate (features south of Church Street)

+ Indicates 2% or less

IV G8 - G9 Blank

GLASS BEADS BY JEREMY HASLAM

No.2 was possibly a Rosary bead and could be earlier than the rest. Not illustrated.

Site A, Church St.

1. Faceted jewel of blue glass. Diameter 11mm. A SF44, L2 (2M, 114/998)
Unstratified.
2. Biconical bead of rather opaque greenish-blue glass. Diameter c.12mm, length 9.5mm, pierced by hole 4.5mm. A SF2035, L2 (2M, 100/998)
Unstratified.
3. Small doughnut-shaped bead of bright green glass, diameter 4mm. A SF1091, L2 (2M, 106/1004) Unstratified.
4. Large spherical bead of smokey pinkish-grey glass with a dab of opaque red and some tiny red specks. Diameter 14.5mm, hole 2mm. A SF2054, F2005, L2021
Early 19th-cent. context.

Site B, Greyfriars

5. & 6. Two opaque turquoise blue globular beads, diameters 13 and 8mm.
B VII SF10, L1. Unstratified (mid 19th-century material).

IV G11 - G13 Blank

LIST OF CONTENTS, FICHE IV

	Fiche
COINS, TOKENS, COUNTERS AND COIN-WEIGHTS IDENTIFIED by N.J. MAYHEW, DAPHNE NASH (NOS.1-2), S.E. RIGOLD (NUREMBERG JETTONS) AND MARION ARCHIBALD (NOS.9, 12)	A3
COPPER ALLOY AND SILVER OBJECTS (FIGS.112-22) by ALISON R. GOODALL; SPURS by BLANCHE ELLIS	B1
LEAD AND LEAD ALLOY OBJECTS (FIGS.123-24) by GEOFF EGAN, ALISON R. GOODALL AND GWYNNE OAKLEY	C11
IRON OBJECTS (FIGS.125-33) by IAN H. GOODALL; SPURS by BLANCHE ELLIS	D1
BONE AND IVORY OBJECTS (FIGS.134-39) by GEOFF EGAN AND MARTIN HENIG; IDENTIFICATION OF BONE AND IVORY by PHILIP ARMITAGE AND BOB WILSON	F1
WOODEN OBJECTS by GWYNNE OAKLEY; SPECIES IDENTIFICATION by M.A. ROBINSON	G1
GLASS (FIGS.140-43) by JEREMY HASLAM	G4
GLASS BEADS by JEREMY HASLAM	G10